

FVRE11S

SERIES

FUJI INVERTERS

Powerful and compact inverters
with dynamic torque-vector control

WARNING

RISK OF INJURY OR ELECTRIC SHOCK
Refer to the user's manual before installation and operation.

RISK OF ELECTRIC SHOCK
Do not remove this cover while applying power and at least 5 min. after disconnecting power. Securely ground (earth) the equipment. Run and stop keys function only in keypad operation mode.

(When function code F02 setting is 0,2 or 3)

WARNING

- **RISK OF INJURY OR ELECTRIC SHOCK**
Refer to the user's manual before installation and operation.
- **RISK OF ELECTRIC SHOCK**
Do not remove this cover while applying power and at least 5 min. after disconnecting power.
- Securely ground (earth) the equipment.
- Run and stop keys function only in keypad operation mode.

FUJI ELECTRIC

RISK OF INJURY OR ELECTRIC SHOCK
Refer to the user's manual before installation and operation.

RISK OF ELECTRIC SHOCK
Do not remove this cover while applying power and at least 5 min. after disconnecting power. Securely ground (earth) the equipment. Run and stop keys function only in keypad operation mode.

(When function code F02 setting is 0,2 or 3)



FUJI ELECTRIC

P

owerful, compact inverters supported by cuttingedge technology. Dynamic torque-vector control promises optimum motor control.

- Even with a compact body size, this series has a high starting torque of 200% at 0.5Hz and motor wow in the low speed range is suppressed to approximately half that of conventional inverters.
- Equipped with intelligent functions such as automatic energy-saving, PID control, auto-tuning, and RS485 communication, and enhanced maintenance/protection functions such as inrush-current suppression and lifetime early warning.



1. Dynamic torque-vector control

Dynamic torque-vector control system performs high-speed calculation to determine the required motor power for the load status. Our exclusive technology promises optimal control of voltage and current vectors for maximum output torque.

- **High starting torque of 200% at 0.5Hz**

Securely used for heavy load such as conveyance of lifting and traversing.

Also available for the second motor by changeover operation.

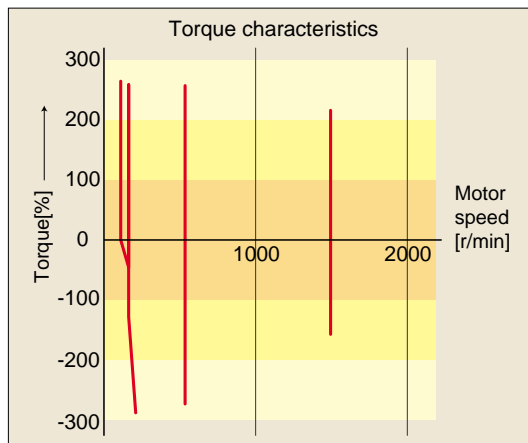

● Trip-free operation

The remarkably improved current limiting function (Automatic deceleration, stall prevention) provides continuous stable operation even for an impact load.

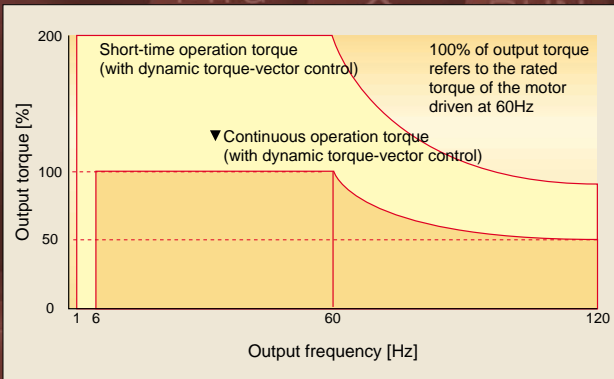

※ The above graph shows an example of torque characteristics when combining FVR-E11S (at dynamic torque-vector control) with Fuji standard three-phase motor (8-type series, 4 poles). Continuous operation torque is for limits of allowable load torque for using the motor within the allowable temperature range and is not for motor output torque.

The motor output torque is shown by the short-time operation torque.

● Reduced motor wow at low speed

Fuji's unique On-Delay compensation method reduces motor wow at low speed to approximately half of that of conventional inverters.

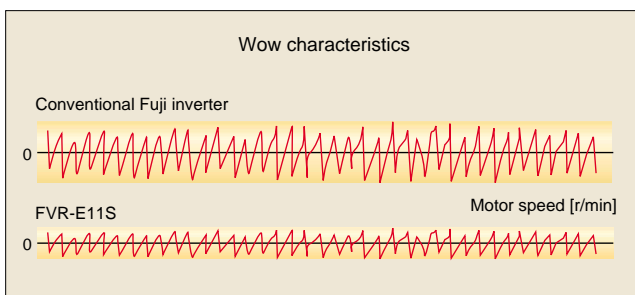

2. Compact



● Miniaturization of minimum level in the class

Compared to the conventional FVR-E9S series, the volume is reduced to approximately 50%. (single-phase 200V, 0.4kW).

● Uniform height dimension

All models up to 4.0kW have a uniform height of 130mm, which makes it easy to design panels.



● Braking resistor connectable to all models

Owing to a built-in braking transistor, an optional braking resistor can be installed to increase the regenerative braking capacity for conveyance and transportation machines that require large braking power.

3. Consideration for peripheral devices



- **Built-in inrush-current suppression circuit as standard**

The capacity of peripheral devices such as magnetic contactor can be minimized.

- **Low noise**

Remarkably reduces influence to devices such as sensors.

- **Equipped with a terminal for connecting DC REACTOR for harmonics suppression**

- **Minimal motor sound driving with higher carrier frequency setting**

- **Selectable control meter outputs (analog/pulse changeover)**

- **24V power source for transistor output**

4. Advanced, convenient functions



- **Equipped automatic energy-saving function as standard**

Since controlling the motor losses to minimum, realizes further electric power-saving.

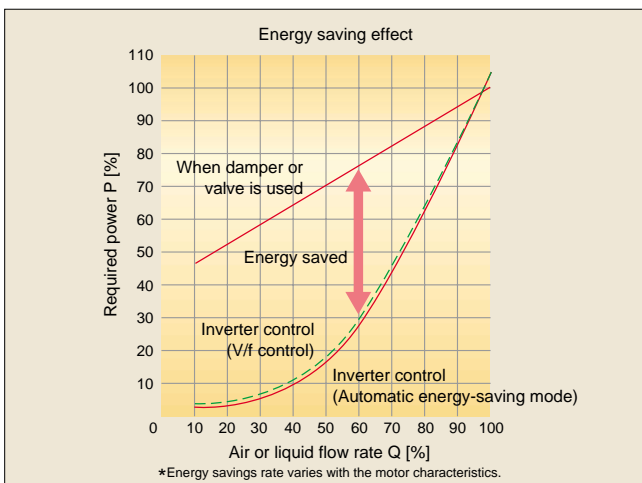

- **New on-line tuning system**

On-line tuning to continuously check for variation of motor characteristics during running for high-precision speed control.

This tuning function also available for a second motor, which allows high-precision driving of the second motor by changeover operation between two motors.

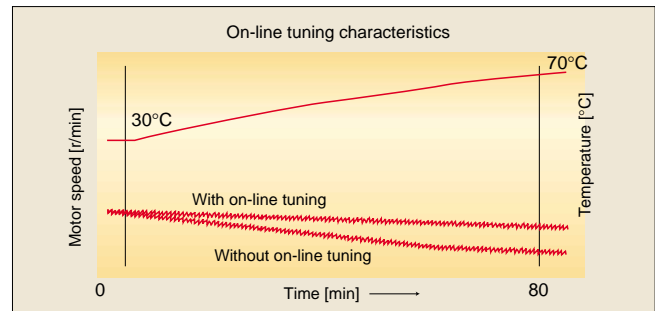

- **Continuous operation after momentary power failure**

Provided with restart mode setting; restart either at output frequency on power failure occurrence or at starting frequency.

- **PID control function**

Equipped with a PID control function which can control the flow rate of fans and pumps in an optimal manner.

- **Various frequency setting methods**

- Keypad operation or analog input (4 to 20mA_{dc}, 0 to +5V_{dc}, 0 to ±10V_{dc}, normal/inverse)
- Multistep speeds, 16-step setting (0 to 15 steps) and UP/DOWN control etc.

- **Equipped with RS485 interface as standard**

5. Wide variation



- **Line-up up to 7.5kW**
Extensively arranged three-phase 400V series, facilitating the unification of applying inverters to machines and equipment.

- **Single-phase 200V series (2.2kW or smaller)**

- **Various indications on the keypad panel**

Indicates output frequency, output current, output voltage, motor speed, trip history, etc.



- **Simple wiring**

Only requires removing covers of the main circuit and control circuit terminal blocks adopting screw terminal, without detaching the keypad panel.

- **Simple function setting by copy unit (Option)**

The optional copy unit (CP-E11S) can set functions in plural inverters in a lump, which can be commonly used for FUJI's C11S series.

6. Protective functions, Maintenance



- **Indication of main circuit capacitor life and accumulated operation time**

- Cooling fan stop operation possible
- Overheat early warning of heat sink
- Protective function of input/output phase loss

8. Global products



- **Conforms to major world safety standards: UL, cUL, TÜV, EN (CE marking)**

- **Complied with EMC Directive (Emission) when connected to optional EMC compliance filter**

- **Connection to field bus: Profibus-DP, Interbus-S, DeviceNet, Modbus Plus, CAN Open (Option)**

7. Easy operation and wiring



- **Simple remote control**

Remote control is available by removing keypad panel and using an optional extension cable (CBR-5S).

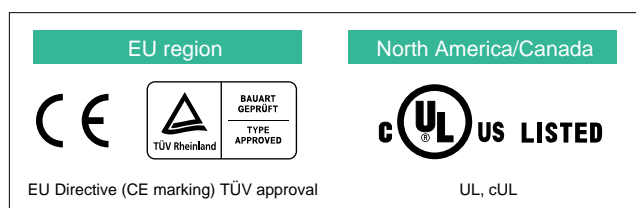
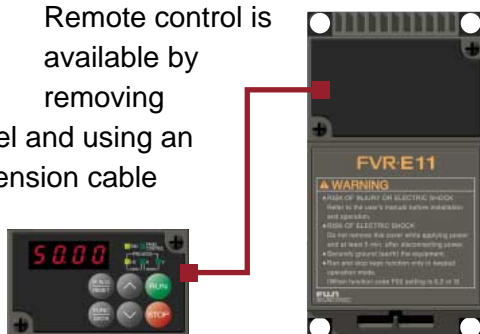

Wide range of inverters: three-phase 400V and single-phase 200V.

| Nominal applied motors [kW] | Three-phase 400V series | Single-phase 200V series |
|-----------------------------|-------------------------|--------------------------|
| 0.1 | | FVR0.1E11S-7EN |
| 0.2 | | FVR0.2E11S-7EN |
| 0.4 | FVR0.4E11S-4EN | FVR0.4E11S-7EN |
| 0.75 | FVR0.75E11S-4EN | FVR0.75E11S-7EN |
| 1.5 | FVR1.5E11S-4EN | FVR1.5E11S-7EN |
| 2.2 | FVR2.2E11S-4EN | FVR2.2E11S-7EN |
| 4.0 | FVR4.0E11S-4EN | |
| 5.5 | FVR5.5E11S-4EN | |
| 7.5 | FVR7.5E11S-4EN | |

How to read the model number

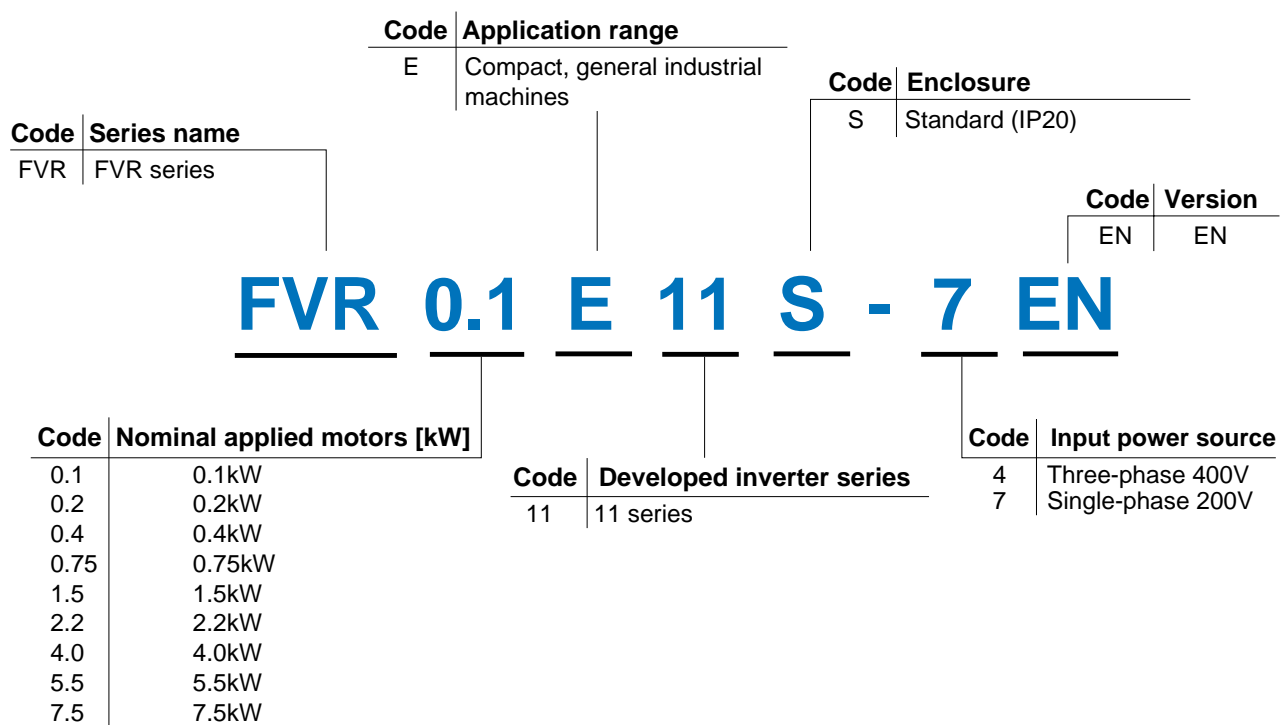

FVR-E11S series. For almost all industrial plant and equipment areas.



Fans

- Air conditioning system
- Dryer
- Boiler fan
- Fans for controlling furnace temperature
- Roof fans controlled as a group
- Refrigerator
- Built-in blower in a film-manufacturing machine
- Fan for separator
- Cooling-tower fans
- Ventilating fans
- Air-conditioning equipment



Electric pumps

- Tankless water-supply system
- Submersible pump
- Vacuum pump
- Fountain pump
- Cooling water pump
- Circulating hot water pump
- Well pump
- Pump for agricultural water storage
- Constant-flow pump
- Sludge pump

Food processing machines

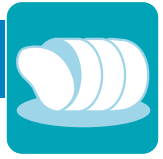

- Food mixer
- Food slicer
- Grain processing machine
- Tea manufacturing machine
- Rice milling machine



Conveyance machinery

- Crane (traveling, traversing, hoisting)
- Automated warehouse
- Conveyor (belt, chain, screw, roller)
- Lift
- Car parking system
- Elevator, escalator
- Automatic door
- Shutter
- Speed changer

Textile/paper making machinery



- Spinning machine
- Knitting machine
- Textile printing machine
- Industrial sewing machine
- Slitter



Packaging machinery



- Individual packing / inner packing
- Packing machine
- Outer packing machine



Chemical machinery/wood working machines

- Fluids mixing machine
- Centrifugal separator
- Coating machine
- Take-up roller
- Router machine
- Sanding machine
- Planing machine



Machine tools

- Boring machine
- Winding machine
- Press
- Turntable
- Work positioning unit
- PC board drilling machine

Other machinery



- Automated feed / medicine mixing machine
- Commercial-use washing machine
- Offset printing press
- Bookbinding machine
- Car washing machine
- Shredder
- Dishwasher
- Test equipment

Standard Specifications

Three-phase 400V series

| | | | | | | | | | |
|------------------------------------|---|--|--|--------------|--------------------------------|--------------|--------------|------------|------------|
| Type | FVR□□□E11S-4EN | 0.4 | 0.75 | 1.5 | 2.2 | 4.0 | 5.5 | 7.5 | |
| Nominal applied motor | kW | 0.4 | 0.75 | 1.5 | 2.2 | 4.0 | 5.5 | 7.5 | |
| Output ratings | Rated capacity *1) | kVA | 1.1 | 1.9 | 2.8 | 4.1 | 6.8 | 13 | |
| | Rated voltage *2) | V | 3-phase 380, 400, 415V/50Hz, 380, 400, 440, 460V/60Hz | | | | | | |
| | Rated current *3) | A | 1.5 (1.4) | 2.5 (2.1) | 3.7 (3.7) | 5.5 (5.3) | 9.0 (8.7) | 13 (12) | 18 (16) |
| | Overload capability | | 150% of rated current for 1min. | | 200% of rated current for 0.5s | | | | |
| | Rated frequency | Hz | 50, 60Hz | | | | | | |
| Input ratings | Phases, Voltage, Frequency | | 3-phase | 380 to 480V | 50/60Hz | | | | |
| | Voltage / frequency variations | | Voltage: +10 to -15% (Voltage unbalance *4): 2% or less) Frequency: +5 to -5% | | | | | | |
| | Momentary voltage dip capability *5) | | When the input voltage is 300V or more, the inverter can be operated continuously. When the input voltage drops below 300V from rated voltage, the inverter can be operated for 15ms. The smooth recovery mode is selectable (by Auto-restart function). | | | | | | |
| | Rated current *6) | (with DCR) A | 0.82 | 1.5 | 2.9 | 4.2 | 7.1 | 10.0 | 13.5 |
| | | (without DCR) | 1.8 | 3.5 | 6.2 | 9.2 | 14.9 | 21.5 | 27.9 |
| Required power supply capacity *7) | kVA | 0.6 | 1.1 | 2.1 | 3.0 | 5.0 | 7.0 | 9.4 | |
| Control | Starting torque | 200% (with Dynamic torque-vector control selected) | | | | | | | |
| Braking | Braking torque (Standard) *8) | 70 | | 40 | | | 20 | | |
| | Braking torque (Using options) | 150 | | | | | | | |
| | DC injection braking | Starting frequency: 0.0 to 60.0Hz Braking time: 0.0 to 30.0s Braking level: 0 to 100% of rated current | | | | | | | |
| Enclosure (IEC 60529) | IP 20 | | | | | | | | |
| Cooling method | Natural cooling | | | | Fan cooling | | | | |
| Standards | -UL/cUL -Low Voltage Directive -EMC Directive -TUV -EN 61800-2 (Ratings, specifications for low voltage adjustable frequency a.c. power drive systems) -EN 61800-3 (EMC product standard including specific test methods) | | | | | | | | |
| Mass | kg | | 1.2 | 1.3 | 1.4 | 1.9 | 4.5 | 4.5 | |

Single-phase 200V series

| | | | | | | | | | |
|------------------------------------|---|--|--|--------------|--------------------------------|--------------|--------------|---------------------|--|
| Type | FVR□□□E11S-7EN | 0.1 | 0.2 | 0.4 | 0.75 | 1.5 | 2.2 | | |
| Nominal applied motor | kW | 0.1 | 0.2 | 0.4 | 0.75 | 1.5 | 2.2 | | |
| Output ratings | Rated capacity *1) | kVA | 0.30 | 0.57 | 1.1 | 1.9 | 3.0 | 4.1 | |
| | Rated voltage *2) | V | 3-phase 200V/50Hz | | | | | 200, 220, 230V/60Hz | |
| | Rated current *3) | A | 0.8 (0.7) | 1.5 (1.4) | 3.0 (2.5) | 5.0 (4.0) | 8.0 (7.0) | 11 (10) | |
| | Overload capability | | 150% of rated current for 1min. | | 200% of rated current for 0.5s | | | | |
| | Rated frequency | Hz | 50, 60Hz | | | | | | |
| Input ratings | Phases, Voltage, Frequency | | 1-phase | 200 to 240V | 50/60Hz | | | | |
| | Voltage / frequency variations | | Voltage: +10 to -10% Frequency: +5 to -5% | | | | | | |
| | Momentary voltage dip capability *5) | | When the input voltage is 165V or more, the inverter can be operated continuously. When the input voltage drops below 165V from rated voltage, the inverter can be operated for 15ms. The smooth recovery mode is selectable (by Auto-restart function). | | | | | | |
| | Rated current *6) | (with DCR) A | 1.2 | 2.0 | 3.5 | 6.5 | 11.8 | 17.7 | |
| | | (without DCR) | 2.3 | 3.9 | 6.4 | 11.4 | 19.8 | 28.5 | |
| Required power supply capacity *7) | kVA | 0.3 | 0.4 | 0.7 | 1.3 | 2.4 | 3.6 | | |
| Control | Starting torque | 200% (with Dynamic torque-vector control selected) | | | | | | | |
| Braking | Braking torque (Standard) *8) | 100 | | 70 | | | 40 | | |
| | Braking torque (Using options) | 150 | | | | | | | |
| | DC injection braking | Starting frequency: 0.0 to 60.0Hz Braking time: 0.0 to 30.0s Braking level: 0 to 100% of rated current | | | | | | | |
| Enclosure (IEC 60529) | IP 20 | | | | | | | | |
| Cooling method | Natural cooling | | | | Fan cooling | | | | |
| Standards | -UL/cUL -Low Voltage Directive -EMC Directive -TUV -EN 61800-2 (Ratings, specifications for low voltage adjustable frequency a.c. power drive systems) -EN 61800-3 (EMC product standard including specific test methods) | | | | | | | | |
| Mass | kg | 0.6 | 0.7 | 0.7 | 1.2 | 1.8 | 1.9 | | |

NOTES:

*1) Inverter output capacity (kVA) at 440V in 400V series, 220V in 200V series. *2) Output voltage cannot exceed the power supply voltage. *3) Current derating may be required in case of low impedance loads such as high frequency motor. Use the inverter at the current () or below where carrier frequency setting is higher than 4kHz (F26: 4 to 15) or the amb. temp. is 40°C or higher. *4) Refer to the IEC 61800-3 (5.2.3). *5) Tested at standard load condition (85% load). *6) This value is under FUJI original calculation method. (Refer to the Technical Information.) *7) When optional power-factor correcting DC REACTOR (DCR) is used. *8) With a nominal applied motor, this value is average torque when the motor decelerates and stops from 60Hz. (It may change according to motor loss.)

Conformity to Low Voltage Directive

The FVR-E11S Series conforms to the Low Voltage Directive with EN50178

Conformity to EMC Directive

- Emission requirement
Foot mount filters in compliance with EN61800-3 are provided for all models (Option).
- Immunity requirement
The FVR-E11S Series inverters meet EN61800-3 as standard.

Common Specifications

| Item | | Explanation |
|--------------------|---|---|
| Output frequency | Maximum frequency | 50 to 400Hz *1) |
| | Base frequency | 25 to 400Hz |
| | Starting frequency | 0.1 to 60.0Hz, Holding time: 0.0 to 10.0s |
| | Carrier frequency *2) | 0.75 to 15kHz |
| | Accuracy (Stability) | <ul style="list-style-type: none"> Analog setting : $\pm 0.2\%$ of Maximum frequency (at $25 \pm 10^\circ\text{C}$) Digital setting : $\pm 0.01\%$ of Maximum frequency (at -10 to $+50^\circ\text{C}$) |
| Setting resolution | <ul style="list-style-type: none"> Analog setting : $1/3000$ of Maximum frequency ex.) 0.02Hz at 60Hz, 0.04Hz at 120Hz, 0.15Hz at 400Hz Digital setting : 0.01Hz at Maximum frequency of up to 99.99Hz (0.1Hz at Maximum frequency of 100.0Hz and above) LINK setting : $1/20000$ of Maximum frequency ex.) 0.003Hz at 60Hz, 0.006Hz at 120Hz, 0.02Hz at 400Hz • 0.01Hz (Fixed) | |
| Control | Control method | <ul style="list-style-type: none"> V/f control (Sinusoidal PWM control) • Dynamic torque-vector control (Sinusoidal PWM control) |
| | Voltage / freq. (V/f) characteristic | Adjustable at base and maximum frequency, with AVR control : 160 to 480V (400V series), 80 to 240V (200V series) |
| | Torque boost | Selectable by load characteristics: Constant torque load (Auto/manual), Variable torque load (Manual) |
| | Operation method | <ul style="list-style-type: none"> • KEYPAD operation : key, key • Digital input signal operation : FWD or REV command, Coast-to-stop command, etc. • LINK operation : RS485 (Standard) Profibus-DP, Interbus-S, DeviceNet, Modbus Plus, CAN Open (Option) |
| | Frequency setting (Frequency command) | <ul style="list-style-type: none"> • KEYPAD operation: or key • External potentiometer (*) : 1 to 5kΩ • Analog input : 0 to +10V DC (0 to +5V DC), 4 to 20mA DC (Reversible) 0 to ± 10V DC (0 to ± 5V DC)Reversible operation by polarized signal can be selected. (Inverse) +10 to 0V DC, 20 to 4mA DC.....Inverse mode operation can be selected. • UP/DOWN control : Output frequency increases when UP signal is ON, and decreases when DOWN signal is ON. • Multistep frequency : Up to 16 different frequencies can be selected by digital input signal. • LINK operation : RS485 (Standard) Profibus-DP, Interbus-S, DeviceNet, Modbus Plus, CAN Open (Option) |
| | Running status signal | Transistor output (2 points) : RUN, FAR, FDT, OL, LU, TL, etc. Relay output (1 point) : Alarm output (for any fault) Analog (or pulse) output (1 point) : Output frequency, Output current, Output torque, etc. |
| | Acceleration / Deceleration time | 0.01 to 3600s : • Independently adjustable acceleration and deceleration • 2 different times are selectable. Mode select : Linear, S-curve (weak), S-curve (strong), Non-linear |
| | Frequency limiter | High and Low limiters can be preset. |
| | Bias frequency | Bias frequency can be preset. |
| | Gain for frequency setting | Gain for frequency setting can be preset. (0.0 to 200.0% ex.) Analog input 0 to +5V DC with 200% gain results in maximum frequency at 5V DC. |
| | Jump frequency control | Jump frequency (3 points) and its common jump hysteresis width (0 to 30Hz) can be preset. |
| | Rotating motor pick up (Flying start) | A rotating motor (including inverse rotating mode) can be smoothly picked up without stopping the motor (speed search method). |
| | Auto-restart after momentary power failure | Automatic restart is available without stopping motor after a momentary power failure (speed search method). When "Smooth recovery" mode is selected, the motor speed drop is held minimum. (The inverter searches the motor speed, and smoothly returns to setting frequency. Even if the motor circuit is temporarily opened, the inverter operates without a hitch.) |
| | Slip compensation | The inverter output frequency is controlled according to the load torque to keep motor speed constant. When the value is set at "0.00" and "Torque-vector" is set at "active", the compensation value automatically selects the Fuji standard motor. Slip compensation can be preset for the second motor. |
| | Droop operation | The motor speed droops in proportion to load torque (-9.9 to 0.0Hz). |
| | Torque limiter | <ul style="list-style-type: none"> • When the motor torque reaches a preset limiting level, this function automatically adjusts the output frequency to prevent the inverter from tripping due to an overcurrent. • Torque limiter 1 and 2 can be individually set, and are selectable with a digital input signal. |
| | PID control | This function can control flowrate, pressure, etc. (with an analog feedback signal.) <ul style="list-style-type: none"> • Reference signal <ul style="list-style-type: none"> • KEYPAD operation (or key) : 0.0 to 100.0% • Voltage input (Terminal 12) : 0 to +10V DC • Current input (Terminal C1) : 4 to 20mA DC • Multistep frequency setting : Setting freq. / Max. freq. X 100 (%) • RS485 : Setting freq. / Max. freq. X 100 (%) • Feedback signal <ul style="list-style-type: none"> • Terminal 12 (0 to +10V DC or +10 to 0V DC) • Terminal C1 (4 to 20mA DC or 20 to 4mA DC) |
| | Automatic deceleration | Torque limiter 1 (Braking) is set at "F41: 0" (Same as Torque limiter 2 (Braking)). • In deceleration: The deceleration time is automatically extended up to 3 times the setting time for tripless operation even if braking resistor not used. • In constant speed operation: Based on regenerative energy, the frequency is increased and tripless operation is active. |
| | Second motor's setting | This function is used for two motors switching operation. <ul style="list-style-type: none"> • The second motor's V/f characteristics (base and maximum frequency) can be preset. • The second motor's circuit parameter can be preset. Torque-vector control can be applied to both motors. |
| | Energy saving operation | This function minimizes inverter and motor losses at light load. |
| Fan stop operation | This function is used for silent operation or extending the fan's lifetime. | |

NOTES: (*) Option

*1) For application at 120Hz or above, please contact FUJI.

*2) Inverter may automatically reduce carrier frequency, in accordance with ambient temperature or output current for protecting inverter.

| | Item | Explanation |
|---|--|---|
| Indication (LED monitor) | Operation mode (Running) | <ul style="list-style-type: none"> • Output frequency (Hz) • Setting frequency (Hz) • Output current (A) • Output voltage (V) • Motor synchronous speed (r/min) |
| | Stopping | Selected setting value or output value |
| | Trip mode | Displays the cause of trip by codes as follows. <ul style="list-style-type: none"> • dBH (Overheating at DB circuit) • OL1 (Motor 1 overload) • OL2 (Motor 2 overload) • OLU (Inverter unit overload) • Er1 (Memory error) • Er2 (KEYPAD panel communication error) • Er3 (CPU error) • Er4 (Option error) • Er5 (Option error) • Er7 (Output phase loss error, impedance unbalance) • Er8 (RS485 error) |
| | Running or trip mode | • Trip history: Cause of trip by code (Even when main power supply is off, trip history data of the last 4 trips are retained.) |
| | Charge lamp | When the DC link circuit voltage is higher than 50V, the charge lamp is ON. |
| Protection | Overload | Protects the inverter by electronic thermal and detection of inverter temperature. |
| | Overvoltage | Detects DC link circuit overvoltage, and stops the inverter. (400V series: 800V DC, 200V series: 400V DC) |
| | Incoming surge | Protects the inverter against surge voltage between the main circuit power line and the ground. |
| | Undervoltage | Detects DC link circuit undervoltage, and stops the inverter. (400V series: 400V DC, 200V series: 200V DC) |
| | Input phase loss | Phase loss protection for power line input. |
| | Overheating | Protects the inverter by detection of inverter temperature. |
| | Short-circuit | Short-circuit protection for inverter output circuit |
| | Ground fault | • Ground fault protection for inverter output circuit (Detecting at start) |
| | Motor overload | <ul style="list-style-type: none"> • Electronic thermal overload relay can be selected for standard motor or inverter motor • Thermal time constant (0.5 to 10.0 minutes) can be preset for a special motor. • The second motor's electronic thermal overload relay can be preset for 2-motor changeover operation. |
| | (Overload early warning) | • Outputs a warning signal at preset level before inverter trip. |
| | DB resistor overheating | • Prevents DB resistor overheating by internal electronic thermal overload relay. (The inverter stops electricity discharge operation to protect the DB resistor.) |
| | Stall prevention | <ul style="list-style-type: none"> • Controls the output frequency to prevent OC (overcurrent) trip when the output current exceeds the limit value during acceleration. • Lowers the output frequency to hold almost constant torque when the output current exceeds the limit value during operation at constant speed. • Controls the output frequency to prevent OU (overvoltage) trip when the DC link circuit voltage exceeds the limit value during deceleration. |
| | Output phase loss | When the inverter executes tuning, detects each phase impedance unbalance. |
| Motor protection by PTC thermistor | When the motor temperature exceeds allowable value, the inverter trips automatically. | |
| Auto reset | When the inverter is tripped, it resets automatically and restarts. | |
| Condition (Installation and operation) | Installation location | Free from corrosive gases, flammable gases, oil mist, dusts, and direct sunlight. Indoor use only. Pollution degree 2 for Low Voltage irrelative. |
| | Altitude | 1000m or less. Applicable to 3000m with power derating (-10%/1000m) |
| | Ambient temperature | -10 to +50 °C |
| | Ambient humidity | 5 to 95%RH (non-condensing) |
| Vibration | 3mm at from 2 to less than 9Hz, 9.8m/s ² at from 9 to less than 20Hz 2m/s ² at from 20 to less than 55Hz, 1m/s ² at from 55 to less than 200Hz | |
| Storage condition | • Temperature : -25 to +65 °C • Humidity : 5 to 95%RH (non-condensing) | |

Keypad panel Operation

The following diagram is for reference only. For detailed wiring diagrams, refer to the relevant instruction manual.

Operation using the factory settings
 Connect the inverter to the power supply and the motor. Then, turn on the power to enable variable speed operation.
[Operation method]

1. Run/Stop Press **RUN** or **STOP** key on the keypad panel.
2. Setting frequency Press **▲** or **▼** key on the keypad panel.

NOTES:

- *1) When connecting an optional DC REACTOR, remove the jumper short bar that connects the terminals [P1] and [P+].
- *2) Keep the control circuit wires at least 100mm away from the main circuit wires and put them in separate ducts to prevent noise and resultant malfunctions. When control wiring crosses the main wiring, ensure that they cross each other at right angles.
- *3) For the wiring of the control circuit, use shielded or twisted wires with the shortest possible length. (When using shielded wires, connect one end of the shields to the inverter ground terminal and leave the other end free.)
- *4) If there is a magnetic contactor or a solenoid close to the inverter, connect a surge suppressor to the coil in parallel connection. Keep the wiring length to a minimum.

External signal input Operation

The following diagram is for reference only. For detailed wiring diagrams, refer to the relevant instruction manual.

Run/Stop operation and frequency setting through external signals
 When "1" is set at **F01**, you can set a frequency by using an input signal for 0 to 10V DC. When "2" is set at **F01**, you can set a frequency by using an input signal for 4 to 20mA DC. In both cases, set "1" at **F02**.

NOTES:

- *1) When connecting an optional DC REACTOR, remove the jumper short bar that connects the terminals [P1] and [P+].
- *2) If there is a magnetic contactor or a solenoid close to the inverter, connect a surge suppressor to the coil in parallel connection. Keep the wiring length to a minimum.
- *3) For the wiring of the control circuit, use shielded or twisted wires with the shortest possible length. When using shielded wires, connect the shields to the inverter ground terminal.
- *4) (THR) terminal function can be used by assigning code "8" (External fault) to any of x1 to x5 terminal (function code E01 to E05).

***External braking resistor (DB)**

Terminal Functions

Terminal Functions

| | Symbol | Terminal name | Function | Remarks | Func. code |
|---------------|--------------------------|--|--|---|-------------------------|
| Main circuit | L1/R, L2/S, L3/T | Power input | Connect a 3-phase power supply. | | |
| | L1/L, L2/N | Power input | Connect a 1-phase power supply. | | |
| | U, V, W | Inverter output | Connect a 3-phase induction motor. | | |
| | P1, P(+) | For DC REACTOR | Connect the DC REACTOR for power-factor correcting or harmonic current reducing. | DC REACTOR: Option | |
| | P(+), N(-) | For DC link circuit | Used for DC bus connection system. | | |
| | P(+), DB | For EXTERNAL BRAKING RESISTOR | Connect the EXTERNAL BRAKING RESISTOR (Option) | | |
| | ⊕ G | Grounding | Ground terminal for inverter chassis (housing). | | |
| Analog input | 13 | Potentiometer power supply | +10V DC power supply for frequency setting POT (POT: 1 to 5k Ω) | * Allowable maximum output current : 10mA | |
| | 12 | Voltage input | * 0 to +10V DC/0 to 100% (0 to +5V DC/0 to 100%) * Reversible operation can be selected by function setting. 0 to \pm 10V DC/0 to \pm 100% (0 to \pm 5V DC/0 to \pm 100%) | * Input impedance: 22k Ω * Allowable maximum input voltage: \pm 15V DC * If input voltage is 10 to 15V DC, the inverter estimates it to 10V DC. | F01, C30 |
| | | (PID control) | Used for PID control reference signal or feedback signal. | | F01, H21 |
| | C1 | Current input | * 4 to 20mA DC/0 to 100% | * Input impedance: 250 Ω | F01 |
| | | (PID control) | Used for PID control reference signal or feedback signal. | | F01, H21 |
| | (PTC-thermistor input) | The PTC-thermistor (for motor protection) can be connected to terminal C1 - 11. | | H26, H27 | |
| Digital input | FWD | Forward operation command | FWD: ON The motor runs in the forward direction. FWD: OFF The motor decelerates and stops. | When FWD and REV are simultaneously ON, the motor decelerates and stops. | F02 |
| | REV | Reverse operation command | REV: ON The motor runs in the reverse direction. REV: OFF The motor decelerates and stops. | * The digital inputs can directly connect to source type output (PNP transistor output) circuit. | |
| | X1 | Digital input 1 | These terminals can be preset as follows. | * ON state maximum input voltage: 2V (maximum sink current : 6mA) * OFF state maximum terminal voltage: 22 to 27V (allowable maximum leakage current: 0.5mA) * The digital inputs can directly connect to source type output (PNP transistor output) circuit. | E01 to E05 |
| | X2 | Digital input 2 | | | |
| | X3 | Digital input 3 | | | |
| | X4 | Digital input 4 | | | |
| | X5 | Digital input 5 | | | |
| | (SS1) (SS2) (SS4) (SS8) | Multistep freq. selection | (SS1) : 2 (0, 1) different frequencies are selectable. (SS1,SS2) : 4 (0 to 3) different frequencies are selectable. (SS1,SS2,SS4) : 8 (0 to 7) different frequencies are selectable. (SS1,SS2,SS4,SS8) : 16 (0 to 15) different frequencies are selectable. | Frequency 0 is set by F01 (or C30). (All signals of SS1 to SS8 are OFF) | C05 to C19 |
| | (RT1) | ACC / DEC time selection | (RT1) : 2 (0, 1) different ACC / DEC times are selectable. | Time 0 is set by F07/F08. | F07, F08 E10, E11 |
| | (HLD) | 3-wire operation stop command | Used for 3-wire operation. (HLD): ON The inverter self-holds FWD or REV signal. (HLD): OFF The inverter releases self-holding. | | |
| | (BX) | Coast-to-stop command | (BX): ON Motor will coast-to-stop. (No alarm signal will be output.) | * The motor restarts from 0Hz by turning off BX with the operation command (FWD or REV) ON. * Assigned to terminal X4 at factory setting. | H11 |
| | (RST) | Alarm reset | (RST): ON Faults are reset. (This signal should be held for more than 0.1s.) | * During normal operating, this signal is ignored. * Assigned to X5 at factory setting. | |
| | (THR) | Trip command (External fault) | (THR): OFF "OH2 trip" occurs and motor will coast-to-stop. | This alarm signal is held internally. | |
| | (Hz2/Hz1) | Freq. set 2 / Freq. set 1 | (Hz2/Hz1): ON Freq. set 2 is effective. | If this signal is changed while the inverter is running, the signal is effective only after the inverter stops. | F01 / C30 |
| | (M2/M1) | Motor 2 / Motor 1 | (M2/M1): ON The motor circuit parameter and V/f characteristics are changed to the second motor's ones. | If this signal is changed while the inverter is running, the signal is effective only after the inverter stops. | P01 to P10 / A10 to A19 |
| | (DCBRK) | DC brake command | (DCBRK): ON The DC injection brake is effective. (In the inverter deceleration mode) | If the operation command(FWD/REV) is input while DC braking is effective, the operation command (FWD/REV) has priority. | F20 to F22 |
| | (TL2/TL1) | Torque limiter 2 / Torque limiter 1 | (TL2/TL1): ON Torque limiter 2 is effective. | | F40, F41 / E16, E17 |
| | (UP) | UP command | (UP): ON The output frequency increases. | When UP and DOWN commands are simultaneously ON, DOWN signal is effective. | F01, C30 |
| | (DOWN) | DOWN command | (DOWN): ON The output frequency decreases. * The output frequency change rate is determined by ACC / DEC time. * Restarting frequency can be selected from 0Hz or setting value at the time of stop. | | |
| | (WE-KP) | Write enable for KEYPAD | (WE-KP): ON The data is changed by KEYPAD. | | |
| (Hz/PID) | PID control cancel | (Hz/PID): ON The PID control is canceled, and frequency setting by KEYPAD (or) is effective. | | H20 to H25 | |
| (IVS) | Inverse mode changeover | (IVS): ON Inverse mode is effective in analog signal input. | If this signal is changed while the inverter is running, the signal is effective only after the inverter stops. | F01, C30 | |
| (LE) | Link enable (RS485, Bus) | (LE): ON The link operation is effective. Used to switch operation between ordinary operation and link operation to communication. | RS485: Standard, Bus: Option | H30 | |
| CM | Common | Common for digital signal | Isolated from CME and 11. | | |

Terminal Functions

| | Symbol | Terminal name | Function | Remarks | Func. code |
|-------------------|------------------------|--|--|---|-------------------|
| Analog output | FM (11) | Analog monitor (Common) | Output voltage (0 to 10V DC) is proportional to selected function's value as follows. The proportional coefficient and bias value can be preset. <ul style="list-style-type: none"> • Output frequency 1 (Before slip compensation) (0 to max. frequency) • Output frequency 2 (After slip compensation) (0 to max. frequency) • Output current (0 to 200%) • Output voltage (0 to 200%) • Output torque (0 to 200%) • Load factor (0 to 200%) • Input power (0 to 200%) • PID feedback value (0 to 100%) • DC link circuit voltage (0 to 1000V) | Allowable maximum output current: 2mA | F29 F30, F31 |
| Pulse output | FM (11) | Pulse rate monitor (Common) | <ul style="list-style-type: none"> • Pulse rate mode : Pulse rate is proportional to selected function's value* (50% duty pulse) • Average voltage mode : Average voltage is proportional to selected function's value* (2670p/s pulse width control) * Kinds of function to be output is same as those of analog output (FM). | Allowable maximum output current : 2mA | F29 F33 to F35 |
| Transistor output | P24 | DC voltage supply | Power supply for transistor output load. (+24V DC, 50mA max.) | Link P24 to CMC and connect loads such as relays between Y1E, Y2E and CM. | |
| | Y1E Y2E | Transistor output 1 Transistor output 2 | Output the selected signals from the following items. | <ul style="list-style-type: none"> • ON state maximum output voltage : 2V (Allowable maximum source current : 50mA) • OFF state maximum leakage current : 0.1mA (Allowable maximum voltage : 27V) | E20, E21 |
| | (RUN) | Inverter running | Outputs ON signal when the output frequency is higher than starting frequency. | | |
| | (FAR) | Frequency equivalence signal | Outputs ON signal when the difference between output frequency and setting frequency is smaller than FAR hysteresis width. | | E30 |
| | (FDT) | Frequency level detection | Outputs ON signal by comparison of output frequency and preset value (level and hysteresis). | | E31, E32 |
| | (LU) | Undervoltage detection signal | Outputs ON signal when the inverter stops by undervoltage while the operation command is ON. | | |
| | (B/D) | Torque polarity | Outputs ON signal in braking or stopping mode, and OFF signal in driving mode. | | |
| | (TL) | Torque limiting | Outputs ON signal when the inverter is in torque-limiting mode. | | |
| | (IPF) | Auto-restarting | Outputs ON signal during auto restart operation (Instantaneous power failure) mode. (including "restart time") | | |
| (OL) | Overload early warning | <ul style="list-style-type: none"> • Outputs ON signal when the electronic thermal value is higher than preset alarm level. • Outputs ON signal when the output current value is higher than preset alarm level. | | E33 to E35 | |
| | CMC | Common (transistor output) | Common for transistor output signal. | Isolated from terminals CM and 11. | |
| Relay output | 30A, 30B 30C | Alarm relay output | Outputs a contact signal when a protective function is activated. Changeable exciting mode active or non-exciting mode active by function "F36". | <ul style="list-style-type: none"> • Contact rating : 250V AC, 0.3A, $\cos\phi=0.3$ 48V DC, 0.5A, non-inductive (for LVD) 42V DC, 0.5A, non-inductive (for UL/cUL) | F36 |
| LINK | | RS485 I/O terminal | Connect the RS485 link signal. | | |

Terminal Arrangement

Main circuit terminals

Control circuit terminals

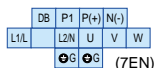
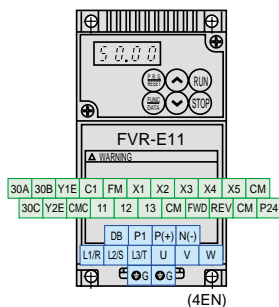

FVR0.1, 0.2, 0.4E11S-7EN

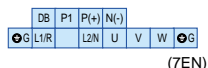
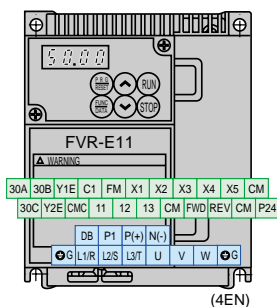

FVR0.4 to 2.2E11S-4EN
FVR0.75E11S-7EN

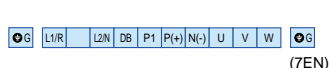
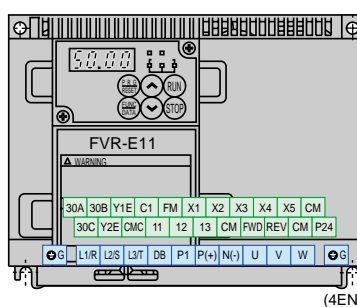

FVR4.0E11S-4EN
FVR1.5, 2.2E11S-7EN

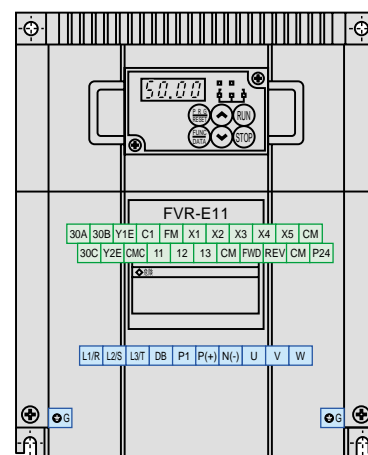

FVR5.5, 7.5E11S-4EN

Keypad Panel Functions and Operations

Keypad panel

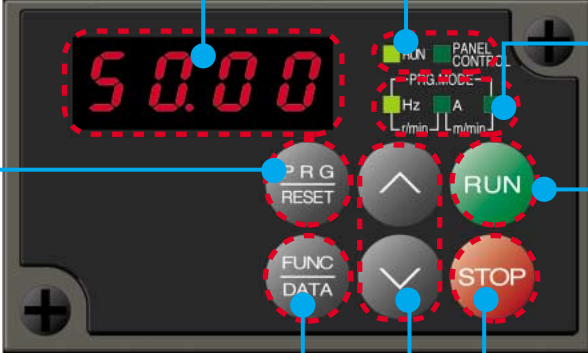

LED monitor
In Operation mode:
 Displays the setting frequency, output current, voltage, motor speed, or line speed.
In Trip mode:
 Displays code indicating the cause of trip.

Operation mode indication
 RUN :
 This LED goes on during operating.
 PANEL CONTROL :
 When Function code **F 0 2** is set at **0 0 0**, **0 0 2**, or **0 0 3** (Keypad operation), this LED goes on.

Unit indication
 Displays the unit of the value shown on the LED monitor.

Program/Reset key
 Switches between operation mode and program mode.
When tripped:
 Releases the trip-stop state and changes to operation mode.

Run key
 Starts the inverter.
In Stop mode:
 Invalid when the function code **F 0 2** is set at **0 0 1** (external operation).

Stop key
 Stops the inverter.
In Operation mode:
 Invalid when the function code **F 0 2** is set at **0 0 1** (external operation).

Function/Data select key
 Changes the displayed values of LED monitor, selects and stores the function codes and data codes.

Up/Down keys
In Operation mode:
 Increases or decreases the frequency or motor speed.
In Program mode:
 Increases or decreases function code number and data set value.

Keypad panel operation

1. Turn on the power supply, press the or key to set the output frequency. When you press the key, the motor will run at the set frequency and with function code/data at factory shipment. When you press the key, the motor will decelerates and stops.

2. Procedure for selecting and changing function codes and data codes.
 The keypad panel operation how to select a function code and change its data code is explained below.

- ① Press the key to select the program mode.
- ② Pressing key alternates the displayed data between the function code and its data.
 (**F 0 0** ▶ **0 0 0** ▶ **F 0 1** ▶ **0 0 0** ▶)
- ③ With data displayed, press the or key to change the data code.
- ④ Press the key to update the data for the selected function code.

* In step ② above, if the or key is pressed when the function code is displayed, only the function code changes sequentially (see below).

(**F 0 0** ▶ **F 0 1** ▶ **F 0 2** ▶ **F 0 3** ▶)



The keypad panel modes are classified in the following 5 modes.

| Monitor, keys | Mode | Program mode (operation stopped) | Program mode (during operation) | Stop mode | Operation mode | Trip mode |
|---------------|--|---|---|---|--|--|
| Monitor | | Displays the function code or data code. (Blinking) | Displays the function code or data code. (Lighting) | Displays the set frequency, output current, output voltage, motor speed, line speed. (Blinking) | Displays the output frequency, output current, output voltage, motor speed, line speed. (Lighting) | Displays the trip content or alarm history. (Blinking or lighting) |
| | | Indicates the PRG mode during stopping. | Indicates the PRG mode during operation. | Unit indication of the above value. | Unit indication of the above value. | None |
| | | | | | | Not lit |
| | <input type="checkbox"/> PANEL CONTROL | Indicates whether keypad panel operation or external signal operation. (ON during keypad panel operation) | | | | None (Lighting) |
| | <input type="checkbox"/> RUN | Indicates the operation has stopped. (<input type="checkbox"/> RUN not lit) | Indicates during operation. (<input checked="" type="checkbox"/> RUN lighting) | Indicates the operation has stopped. (<input type="checkbox"/> RUN not lit) | Indicates during operation. (<input checked="" type="checkbox"/> RUN lighting) | Indicates "stopping in trip mode." (<input checked="" type="checkbox"/> RUN lighting) |
| Keys | | Switches to the stop mode. | Changes to operation mode. | Switches to "Program mode (operation stopped)." | Switches to "Program mode during operation." | Releases the trip and switches to "stop mode" or "operation mode." |
| | | Changes the display between function code and data code, stores data code, and then updates function codes. | | Shifts the value on the LED monitor and the unit of the unit indication LED. | | Invalid |
| | | Increases/decreases function code number and data code. | | Increases/decreases the setting of frequency, motor speed, line speed. | | Displays the alarm history. |
| | | Invalid | Invalid | Switches to operation mode. | Invalid | Invalid |
| | | Invalid | Switches to "stop mode" or "Program mode (operation stopped)." | Invalid | Switches to the stop mode. | Invalid |

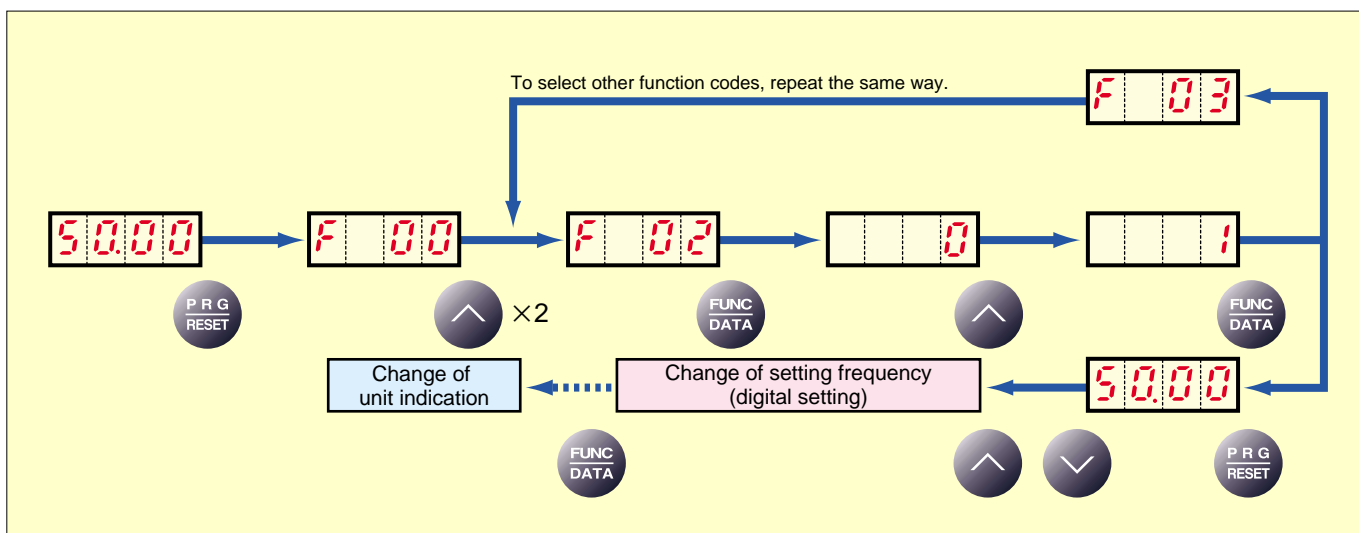

* Procedure for selecting function codes and data codes (Ex. Changing data code from to of function code)



Function settings

The functions in the yellow boxes can be set while the inverter is running. Other functions must be set while the inverter is stopped.

Fundamental Functions

| | Function Code | Name | Setting range | Min. unit | Factory setting |
|-----------------|----------------------------|---|---|-----------|-----------------|
| Basic Functions | F00 | Data protection | 0 : Data change enable 1 : Data protection | - | 0 |
| | F01 | Frequency command 1 | 0 : KEYPAD operation ( or  key) 1 : Voltage input (terminal 12) (0 to +10V DC, 0 to +5V DC) 2 : Current input (terminal C1) (4 to 20mA DC) 3 : Voltage and current input (terminals 12 and C1) 4 : Reversible operation with polarity (terminal 12)(0 to ±10V DC) 5 : Inverse mode operation (terminal 12) (+10 to 0V DC) 6 : Inverse mode operation (terminal C1) (20 to 4mA DC) 7 : UP/DOWN control 1 (initial freq. = 0Hz) 8 : UP/DOWN control 2 (initial freq. = last value) | - | 0 |
| | F02 | Operation method | 0 : KEYPAD operation (forward/reverse : by signal input) 1 : FWD or REV command signal operation 2 : KEYPAD operation (FWD) 3 : KEYPAD operation (REV) | - | 2 |
| | F03 | Maximum frequency 1 | 50 to 400Hz | 1Hz | 50 |
| | F04 | Base frequency 1 | 25 to 400Hz | 1Hz | 50 |
| | F05 | Rated voltage 1 (at Base frequency 1) | 0(Free), 160 to 480V (400V class) 0(Free), 80 to 240V (200V class) | 1V | 400 230 |
| | F06 | Maximum voltage 1 (at Maximum frequency 1) | 160 to 480V (400V class) 80 to 240V (200V class) | 1V | 400 230 |
| | F07 | Acceleration time 1 | 0.01 to 3600s | 0.01s | 6.00 |
| | F08 | Deceleration time 1 | 0.01 to 3600s | 0.01s | 6.00 |
| | F09 | Torque boost 1 | 0 : Automatic (for constant torque load) 1 : Manual (for variable torque load) 2 : Manual (for proportional torque load) 3 to 31 : Manual (for constant torque load) | 1 | 0 |
| | F10 | Electronic thermal overload relay for motor 1 (Select) | 0 : Inactive 1 : Active (for 4-pole standard motor) 2 : Active (for 4-pole inverter motor) | - | 1 |
| | F11 | (Level) | Approx. 20 to 135% of rated current | 0.01A | *1) |
| | F12 | (Thermal time constant) | 0.5 to 10.0 min | 0.1min | 5.0 |
| | F13 | Electronic thermal overload relay (for braking resistor) | 0 : Inactive 1 : Active (for external braking resistor : DB□□-□□C) 2 : Active (for external braking resistor : TK80W 120Ω; Single phase only) | - | 0 |
| | F14 | Restart mode after momentary power failure | 0 : Inactive (Trip and alarm when power failure occurs.) 1 : Inactive (Trip, and alarm when power recovers.) 2 : Inactive (Deceleration stop, and alarm.) 3 : Active (Momentarily stops and restarts at output frequency of before power failure) 4 : Active (Momentarily stops and restarts at starting frequency) | - | 0 |
| | F15 | Frequency limiter (High) | 0 to 400Hz | 1Hz | 70 |
| | F16 | limiter (Low) | 0 to 400Hz | 1Hz | 0 |
| | F17 | Gain (for frequency setting signal) | 0.0 to 200.0% | 0.1% | 100.0 |
| | F18 | Bias frequency | -400 to +400Hz | 1Hz | 0 |
| | F20 | DC brake (Starting freq.) | 0.0 to 60.0Hz | 0.1Hz | 0.0 |
| | F21 | (Braking level) | 0 to 100% | 1% | 0 |
| | F22 | (Braking time) | 0.0 (DC brake inactive), 0.1 to 30.0s | 0.1s | 0.0 |
| | F23 | Starting frequency (Freq.) | 0.1 to 60.0Hz | 0.1Hz | 0.5 |
| | F24 | (Holding time) | 0.0 to 10.0s | 0.1s | 0.0 |
| | F25 | Stop frequency | 0.1 to 6.0Hz | 0.1Hz | 0.2 |
| | F26 | Motor sound (Carrier freq.) | 0.75 to 15kHz | 1kHz | 15 |
| | F27 | (Sound tone) | 0 : Level 0 1 : Level 1 2 : Level 2 3 : Level 3 | - | 0 |
| | F29 | FMA, FMP (Select) | 0 : Analog output (FMA) 1 : Pulse output (FMP) | - | 0 |
| | F30 | FM (Voltage adjust) | 0 to 200% | 1% | 100 |
| | F31 | (Function) | 0 : Output frequency 1 (Before slip compensation) 1 : Output frequency 2 (After slip compensation) 2 : Output current 3 : Output voltage 4 : Output torque 5 : Load factor 6 : Input power 7 : PID feedback value 8 : DC link circuit voltage | - | 0 |
| F33 | FM (Pulse rate) | 300 to 6000 p/s (at full scale) | 1p/s | 1440 | |
| F34 | (Voltage adjust) | 0% : (Pulse rate output: 50% duty) 1 to 200% : (Voltage adjust: 2670p/s, duty adjust) | 1% | 0 | |
| F35 | (Function) | 0 : Output frequency 1 (Before slip compensation) 1 : Output frequency 2 (After slip compensation) 2 : Output current 3 : Output voltage 4 : Output torque 5 : Load factor 6 : Input power 7 : PID feedback value 8 : DC link circuit voltage | - | 0 | |
| F36 | 30Ry operation mode | 0 : The relay (30) excites on trip mode. 1 : The relay (30) excites on normal mode. | - | 0 | |
| F40 | Torque limiter 1 (Driving) | 20 to 200, 999% (999: No limit) *2) | 1% | 180 | |
| F41 | (Braking) | 20 to 200, 999% (999: No limit) *2) | 1% | 150 | |
| F42 | Torque-vector control 1 | 0 : Inactive 1 : Active | - | 0 | |

NOTES:

*1) Typical value of standard Fuji 4P motor.

*2) Percent shall be set according to FUNCTION CODE : P02 or A11, Motor capacity.

The functions in the yellow boxes can be set while the inverter is running. Other functions must be set while the inverter is stopped.

Extension Terminal Functions

| Function Code | Name | Setting range | Min. unit | Factory setting |
|------------------------|---|--|--|-----------------|
| X1-X5 Terminal | E01 X1 terminal function | Selects from the following items. | - | 0 |
| | E02 X2 terminal function | 0 :) | - | 1 |
| | E03 X3 terminal function | 1 :) Multistep freq. selection (16 steps) | - | 2 |
| | E04 X4 terminal function | 2 :) | - | 6 |
| | E05 X5 terminal function | 3 :) | - | 7 |
| | | 4 : ACC / DEC time selection (1 step) | | |
| | | 5 : 3-wire operation stop command | | |
| | | 6 : Coast-to-stop command | | |
| | | 7 : Alarm reset | | |
| | | 8 : Trip command (External fault) | | |
| | | 9 : Freq. set. 2 / Freq. set. 1 | | |
| | | [SS1] 10 : Motor 2 / Motor 1 | | |
| | | [SS2] 11 : DC brake command | [M2/M1] | |
| | | [SS4] 12 : Torque limiter 2 / Torque limiter 1 | [TL2/TL1] | |
| | | [SS8] 13 : UP command | [UP] | |
| | | [RT1] 14 : DOWN command | [DOWN] | |
| | | [HLD] 15 : Write enable for KEYPAD | [WE-KP] | |
| | | [BX] 16 : PID control cancel | [Hz/PID] | |
| | | [RST] 17 : Inverse mode changeover (terminals 12 and C1) | [IVS] | |
| | | [THR] 18 : Link enable (Bus.RS485) | [LE] | |
| ACC 2 | E10 Acceleration time 2 | 0.01 to 3600s | 0.01s | 10.0 |
| DEC 2 | E11 Deceleration time 2 | | 0.01s | 10.0 |
| | E16 Torque limiter 2 (Driving) | 20 to 200%, 999% (999: No limit) *2) | 1% | 180 |
| | E17 (Braking) | 0 (Automatic deceleration control), 20 to 200%, 999% (999: No limit) *2) | 1% | 150 |
| Y1, Y2 Terminal | E20 Y1 terminal function | Selects from the following items. | - | 0 |
| | E21 Y2 terminal function | 0 : Inverter running | - | 7 |
| | | 1 : Frequency equivalence signal | [RUN] 5 : Torque limiting | [TL] |
| | | 2 : Frequency level detection | [FAR] 6 : Auto-restarting | [IPF] |
| | | 3 : Undervoltage detection signal | [FDT] 7 : Overload early warning | [OL] |
| | | 4 : Torque polarity detection (Braking/Driving) | [LU] 8 : Lifetime alarm (main circuit capacitor) | [LIFE] |
| | | | [B/D] 9 : 2nd Freq. equivalence detection | [FAR2] |
| | E29 Frequency equivalence delay | 0.01 to 10.0s | 0.01s | 0.1 |
| | E30 FAR function signal (Hysteresis) | 0.0 to 10.0 Hz | 0.1Hz | 2.5 |
| | E31 FDT function signal (Level) | 0 to 400 Hz | 1Hz | 50 |
| | E32 (Hysteresis) | 0.0 to 30.0 Hz | 0.1Hz | 1.0 |
| | E33 OL function signal (Mode select) | 0 : Thermal calculation | - | 0 |
| | | 1 : Output current | | |
| | E34 (Level) | Approx. 20 to 200% of rated current | 0.01A | *1 |
| | E35 (Timer) | 0.0 to 60.0s | 0.1s | 10.0 |
| LED Monitor | E39 Display coefficient for constant rate of feeding time | 0.000 to 9.999 | 0.001 | |
| | E40 Display coefficient A / Feeding amount (for constant rate of feeding time) | 0.00 to 200.0 0.00 to 200.0m | 0.01 0.01m | 0.01 |
| | E41 Display coefficient B | 0.00 to 200.0 | 0.01 | 0.00 |
| | E42 LED Display filter | 0.0 to 5.0s | 0.1s | 0.5 |

The functions in the yellow boxes can be set while the inverter is running. Other functions must be set while the inverter is stopped.

Control Functions of Frequency

| Function Code | Name | Setting range | Min. unit | Factory setting |
|-------------------------|--|--|-----------|-----------------|
| Jump Hz Control | C01 Jump frequency (Jump freq. 1) | 0 to 400Hz | 1Hz | 0 |
| | C02 frequency (Jump freq. 2) | | 1Hz | 0 |
| | C03 (Jump freq. 3) | | 1Hz | 0 |
| | C04 (Hysteresis) | 0 to 30Hz | 1Hz | 3 |
| Multi-Hz Control | C05 Multistep frequency (Freq. 1) | 0.00 to 400.0Hz | 0.01Hz | 0.00 |
| | C06 frequency (Freq. 2) | | 0.01Hz | 0.00 |
| | C07 setting (Freq. 3) | | 0.01Hz | 0.00 |
| | C08 (Freq. 4) | | 0.01Hz | 0.00 |
| | C09 (Freq. 5) | | 0.01Hz | 0.00 |
| | C10 (Freq. 6) | | 0.01Hz | 0.00 |
| | C11 (Freq. 7) | | 0.01Hz | 0.00 |
| | C12 (Freq. 8) | | 0.01Hz | 0.00 |
| | C13 (Freq. 9) | | 0.01Hz | 0.00 |
| | C14 (Freq. 10) | | 0.01Hz | 0.00 |
| | C15 (Freq. 11) | | 0.01Hz | 0.00 |
| | C16 (Freq. 12) | | 0.01Hz | 0.00 |
| | C17 (Freq. 13) | | 0.01Hz | 0.00 |
| | C18 (Freq. 14) | | 0.01Hz | 0.00 |
| | C19 (Freq. 15) | | 0.01Hz | 0.00 |
| Timer Operation | C21 Timer operation | 0 : Inactive 1 : Active | - | 0 |
| | C22 (Stage 1) | • Operation time: 0.00 to 3600s | 0.01s | 0.00 |
| | C30 Frequency command 2 | 0 : KEYPAD operation (or key) to 8 : UP/DOWN control 2 (initial freq. = last value) | - | 2 |
| | C31 Offset (Terminal 12) | -5.0 to +5.0% | 0.1% | 0.0 |
| | C32 (Terminal C1) | -5.0 to +5.0% | 0.1% | 0.0 |
| | C33 Analog setting signal filter | 0.00 to +5.00s | 0.01s | 0.05 |

The functions in the yellow boxes can be set while the inverter is running. Other functions must be set while the inverter is stopped.

Motor Parameters

| Function Code | Name | Setting range | Min. unit | Factory setting |
|----------------|--|---|-----------|-----------------|
| Motor 1 | P01 Number of motor 1 poles | 2 to 14 | 2 | 4 |
| | P02 Motor 1 (Capacity) | 3.7kW or smaller : 0.01 to 5.50 kW 5.5kW or larger : 0.01 to 11.00 kW | 0.01kW | *1) |
| | P03 (Rated current) | 0.00 to 99.9 A | 0.01A | *1) |
| | P04 (Tuning) | 0 : Inactive 1 : Active (One time tuning of %R1 and %X (on motor stopping mode)) 2 : Active (One time tuning of %R1, %X and lo (on motor running mode)) | - | 0 |
| | P05 (On-line Tuning) | 0 : Inactive 1 : Active (Real time tuning of %R2) | - | 0 |
| | P06 (No-load current) | 0.00 to 99.9 A | 0.01A | *1) |
| | P07 (%R1 setting) | 0.00 to 50.00 % | 0.01% | *1) |
| | P08 (%X setting) | 0.00 to 50.00 % | 0.01% | *1) |
| | P09 (Slip compensation control 1) | 0.00 to +15.00Hz | 0.01Hz | 0.00 |
| | P10 (Slip compensation response time) | 0.01 to 10.00s | 0.01s | 0.50 |

Function settings

The functions in the yellow boxes can be set while the inverter is running. Other functions must be set while the inverter is stopped.

High Performance Functions

| | Function Code | Name | Setting range | Min. unit | Factory setting | |
|----------------------------|---------------|--|---|---|-----------------|---|
| High Performance Functions | H01 | Accumulated operation time | Monitoring only | 1h | 0 | |
| | H02 | Trip history | Monitoring only | - | - | |
| | H03 | Data initializing (Data reset) | 0 : Manual set value 1 : Return to factory set value | - | 0 | |
| | H04 | Auto-reset (Times) | 0 (Inactive), 1 to 10 times | 1 | 0 | |
| | H05 | (Reset interval) | 2 to 20s | 1s | 5 | |
| | H06 | Fan stop operation | 0 : Inactive 1 : Active (Fan stops at low temperature mode) for 1.5kW or larger model only | - | 0 | |
| | H07 | ACC/DEC pattern (Mode select) | 0 : Linear 2 : S-curve (strong) 1 : S-curve (weak) 3 : Non-linear (For variable torque load) | - | 0 | |
| | H09 | Start mode (Rotating motor pick up) | 0 : Inactive 1 : Active (Only when Auto-restart after momentary power failure mode) 2 : Active (All start modes) | - | 1 | |
| | H10 | Energy-saving operation | 0 : Inactive 1 : Active (Only when torque boost "F09" is set at manual setting mode.) | - | 0 | |
| | H11 | DEC mode | 0 : Normal (according to "H07" mode) 1 : Coast-to-stop | - | 0 | |
| | H12 | Instantaneous overcurrent limiting | 0 : Inactive 1 : Active | - | 1 | |
| | H13 | Auto-restart (Restart time) | 0.1 to 5.0s | 0.1s | 0.1 | |
| | H14 | (Freq. fall rate) | 0.00 to 100.00Hz/s | 0.01Hz/s | 10.00 | |
| | PID Control | H20 | PID control (Mode select) | 0 : Inactive 1 : Active (PID output 0 to 100% / Frequency 0 to max.) 2 : Active (Inverse operation mode : PID output 0 to 100% / Frequency max. to 0) | - | 0 |
| H21 | | (Feedback signal) | 0 : Terminal 12 (0 to +10V) 2 : Terminal 12 (+10 to 0V) 1 : Terminal C1 (4 to 20mA) 3 : Terminal C1 (20 to 4mA) | - | 1 | |
| H22 | | (P-gain) | 0.01 to 10.00 | 0.01 | 0.10 | |
| H23 | | (I-gain) | 0.0 : Inactive 0.1 to 3600s | 0.1s | 0.0 | |
| H24 | | (D-gain) | 0.00 : Inactive 0.01 to 10.0s | 0.01s | 0.00 | |
| Y1, Y2 Terminal | H25 | (Feedback filter) | 0.0 to 60.0s | 0.1s | 0.5 | |
| | H26 | PTC thermistor (Mode select) | 0 : Inactive 1 : Active | - | 0 | |
| | H27 | (Level) | 0.00 to 5.00V | 0.01V | 1.60 | |
| Serial Link | H28 | Droop operation | -9.9 to 0.0Hz | 0.1Hz | 0.0 | |
| | H30 | Serial link (Function select) | (Code) (Monitor) (Frequency command) (Operation command) 0 : X - - X : Valid 1 : X X - - - : Invalid 2 : X - X 3 : X X X | - | 0 | |
| | H31 | RS 485 (Address) | 1 to 31 | 1 | 1 | |
| | H32 | (Mode select on no response error) | 0 : Trip and alarm (Er8) 1 : Operation for H33 timer, and alarm (Er8) 2 : Operation for H33 timer, and retry to communicate. * If the retry fails, then the inverter trips ("Er 8"). 3 : Continuous operation | - | 0 | |
| | H33 | (Timer) | 0 to 60.0s | 0.1s | 2.0 | |
| | H34 | (Baud rate) | 0 : 19200 bit/s 2 : 4800 1 : 9600 3 : 2400 4 : 1200 | - | 1 | |
| | H35 | (Data length) | 0 : 8 bit 1 : 7 bit | - | 0 | |
| | H36 | (Parity check) | 0 : No checking 1 : Even parity 2 : Odd parity | - | 0 | |
| | H37 | (Stop bits) | 0 : 1 bit 1 : 2 bit | - | 0 | |
| | H38 | (No response error detection time) | 0 (No detection), 1 to 60s | 1s | 0 | |
| | H39 | (Response interval) | 0.00 to 1.00s | 0.01s | 0.01 | |
| | Diagnostic | H40 | Maximum temperature of heat sink | Monitoring only | °C | - |
| | | H41 | Maximum effective current | Monitoring only | A | - |
| H42 | | Main circuit capacitor lifetime | Monitoring only | 0.1% | - | |
| H43 | | Cooling fan accumulated operation time | Monitoring only | 10h | - | |
| H44 | | Inverter ROM version | Monitoring only | - | - | |
| H45 | | Keypad panel ROM version | Monitoring only | - | - | |
| H46 | | Option ROM version | Monitoring only | - | - | |

The functions in the yellow boxes can be set while the inverter is running. Other functions must be set while the inverter is stopped.

Alternative Motor Parameters

| | Function Code | Name | Setting range | Min. unit | Factory setting |
|---------|---------------|--|---|-----------|-----------------|
| Motor 2 | R01 | Maximum frequency 2 | 50 to 400Hz | 1Hz | 50 |
| | R02 | Base frequency 2 | 25 to 400Hz | 1Hz | 50 |
| | R03 | Rated voltage 2 (at Base frequency 2) | 0 (Free), 160 to 480V (400V class) 0 (Free), 80 to 240V (200V class) | 1V | 400 230 |
| | R04 | Maximum voltage 2 (at Maximum frequency 2) | 160 to 480V (400V class) 80 to 240V (200V class) | 1V | 400 230 |
| | R05 | Torque boost 2 | 0 : Automatic (for constant torque load) 1 : Manual (for variable torque load) 2 : Manual (for proportional torque load) 3 : Manual (for constant torque load) | - | 0 |
| | R06 | Electronic thermal overload relay for motor 2 (Select) | 0 : Inactive 1 : Active (for 4-pole standard motor) 2 : Active (for 4-pole inverter motor) | - | 1 |
| | R07 | (Level) | Approx. 20 to 135% of rated current | 0.01A | *1) |
| | R08 | (Thermal time constant) | 0.5 to 10.0 min | 0.1min | 5.0 |
| | R09 | Torque vector control 2 | 0 : Inactive 1 : Active | - | 0 |
| | R10 | Number of motor 2 poles | 2 to 14 | 2 | 4 |
| | R11 | Motor 2 (Capacity) | 0.01 to 11.00 kw | 0.01kW | *1) |
| | R12 | (Rated current) | 0.00 to 99.9 A | 0.01A | *1) |
| | R13 | (Tuning) | 0 : Inactive 1 : Active (One time tuning of %R1 and %X (on motor stopping mode)) 2 : Active (One time tuning of %R1, %X and I _o (on motor running mode)) | - | 0 |
| | R14 | (On-line Tuning) | 0 : Inactive 1 : Active (Real time tuning of %R1 and %X) | - | 0 |
| | R15 | (No-load current) | 0.00 to 99.9 A | 0.01A | *1) |
| | R16 | (%R1 setting) | 0.00 to 50.00 % | 0.01% | *1) |
| | R17 | (%X setting) | 0.00 to 50.00 % | 0.01% | *1) |
| | R18 | Slip compensation control 2 | 0.00 to +15.00 Hz | 0.01Hz | 0.00 |
| | R19 | (Slip compensation response time) | 0.01 to 10.00 s | 0.01s | 0.5 |

| Function | Description | | LED monitor |
|---|---|---|--|
| Overcurrent protection (Short-circuit) (Ground fault) | <ul style="list-style-type: none"> Stops running to protect inverter from an overcurrent resulting from overload. Stops running to protect inverter from an overcurrent due to a short-circuit in the output circuit. Stops running to protect inverter from an overcurrent due to a ground fault in the output circuit. | | During acceleration OC 1 |
| | | | During deceleration OC 2 |
| | | | While running at constant speed OC 3 |
| Overvoltage protection | The inverter stops when it detects an overvoltage in the DC link circuit. | <ul style="list-style-type: none"> 400V series : 800V DC or more 200V series : 400V DC or more Protection is not assured if excess AC line voltage is applied inadvertently. | During acceleration OU 1 |
| | | | During deceleration OU 2 |
| | | | While running at constant speed OU 3 |
| Incoming surge protection | <ul style="list-style-type: none"> Protects the inverter against surge voltage between the main circuit power line and ground. Protects the inverter against surge voltage in the main circuit power line. | • The inverter may be tripped by some other protective function. | |
| Undervoltage protection | Stops the inverter when the DC link circuit voltage drops below undervoltage level. | <ul style="list-style-type: none"> 400V series : 400V DC or less 200V series : 200V DC or less | LU |
| Input phase loss protection | The inverter is protected from being damaged when open-phase fault occurs. | | Lin |
| Overheat protection | Stops the inverter when it detects excess heat sink temperature in case of cooling fan failure or overload. | | OH 1 |
| | When the external braking resistor overheats, the inverter stops discharging and running. | | dbH |
| Electronic thermal overload relay (Motor protection) | This function stops the inverter by detecting an inverter overload. | | OLU |
| | This function stops the inverter by detecting an overload in a standard motor or inverter motor. | | Motor 1 overload OL 1 Motor 2 overload OL 2 |
| Stall prevention (Momentary overcurrent limitation) | When an output current exceeds the limit during acceleration, this function lowers output frequency to prevent the occurrence of an OC1 trip. | • The stall prevention function can be disabled. | |
| External alarm input | The inverter stops on receiving external alarm signals. | • Use THR terminal function (digital input). | OH 2 |
| Alarm output (for any fault) | The inverter outputs a relay contact signal when the inverter issued an alarm and stopped. | <ul style="list-style-type: none"> Output terminals: 30A, 30B, and 30C Use the RST terminal function for signal input. | |
| Alarm reset command | An alarm-stop state of the inverter can be cleared with the RESET key or by a digital input signal (RST). | • Even if main power input is turned off, alarm history and trip-cause data are retained. | |
| Alarm history memory | Stores up to four instances of previous alarm data. | | |
| Storage of data on cause of trip | The inverter can store and display details of the latest alarm history data. | | |
| Memory error | The inverter checks memory data after power-on and when the data is written. If a memory error is detected, the inverter stops. | | Er 1 |
| KEYPAD panel communication error | If an error is detected in communication between the inverter and KEYPAD when the Keypad panel is being used, the inverter stops. | • When operated by external signals, the inverter continues running. The alarm output (for any fault) is not output. Only Er2 is displayed. | Er 2 |
| CPU error | If the inverter detects a CPU error caused by noise or some other factor, the inverter stops. | | Er 3 |
| Option communication error | If a checksum error or disconnection is detected during communication, the inverter issues an alarm. | | Er 4 |
| Option error | If a linkage error or other option error is detected, the inverter issues an alarm. | | Er 5 |
| Output phase loss error | If an unbalance of output circuits is detected during tuning, this function issues an alarm (and stops the inverter). | | Er 7 |
| RS485 communication error | If an RS485 communication error is detected, the inverter issues an alarm. | | Er 8 |

NOTES :

- Retaining alarm signal when auxiliary control power supply is not used :
If the inverter power supply is cut off while an internal alarm signal is being output, the alarm signal cannot be retained.
- To issue the RESET command, press the  key on the KEYPAD panel or connect terminals RST and CM once and disconnect them afterwards.
- Fault history data is stored for the past four trips.

External Dimensions

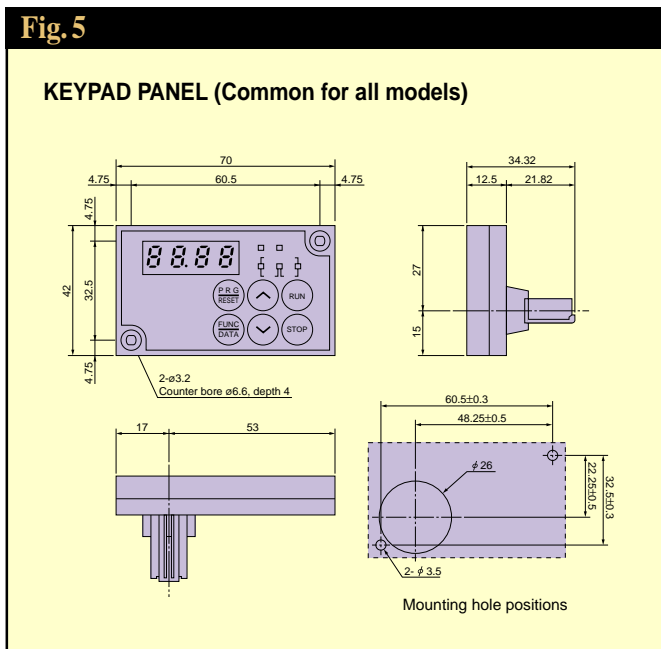
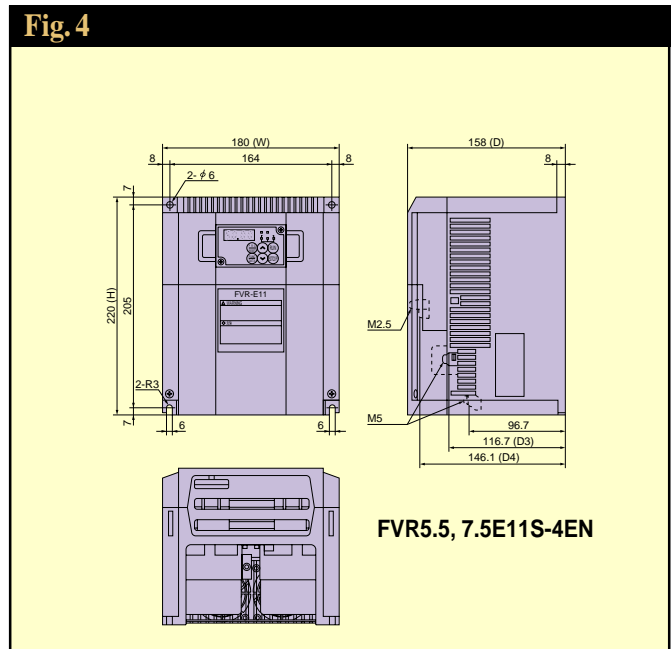
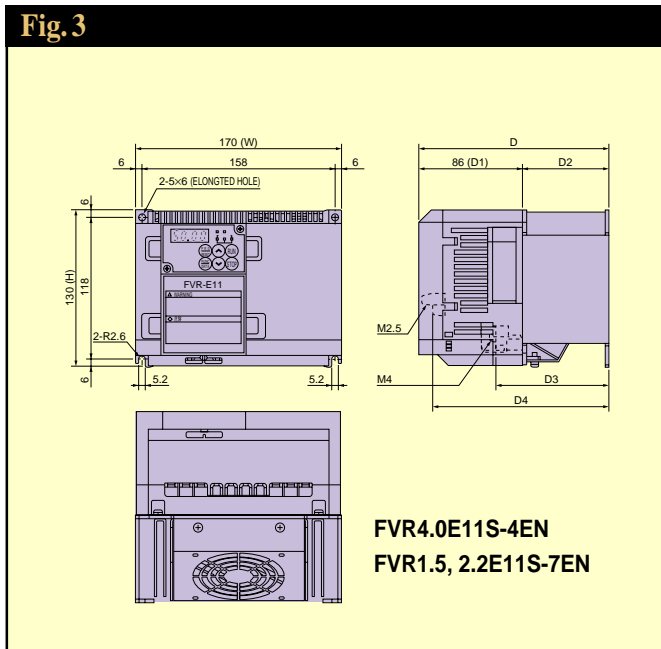
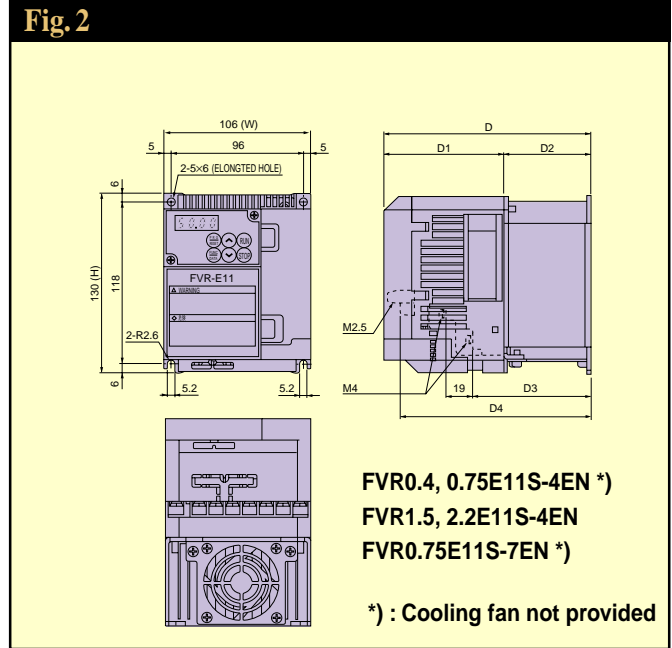
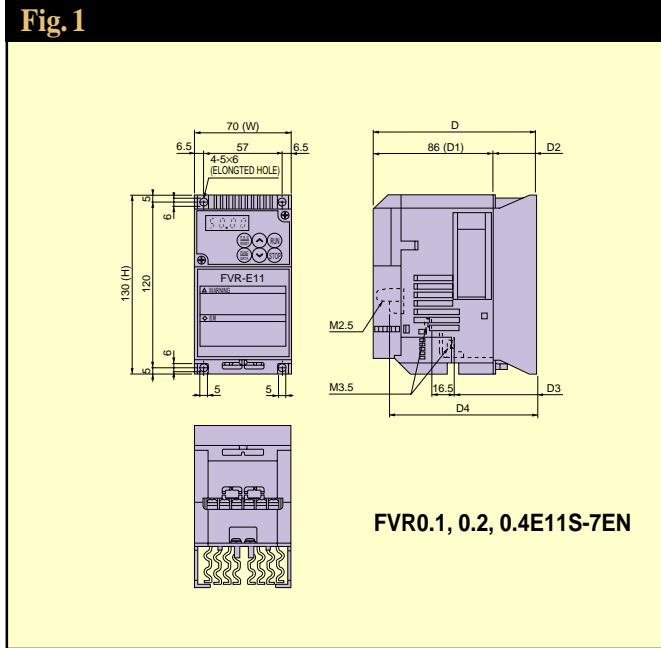

| Power supply voltage | Nominal applied motor(kW) | Type | Dimensions(mm) | | | | | | | Fig. |
|----------------------|---------------------------|-----------------|----------------|-----|-----|-----|----|------|------|------|
| | | | W | H | D | D1 | D2 | D3 | D4 | |
| Three phase 400V | 0.4 | FVR0.4E11S-4EN | 106 | 130 | 126 | 86 | 40 | 62.5 | 115 | 2 |
| | 0.75 | FVR0.75E11S-4EN | 106 | 130 | 150 | 86 | 64 | 86.5 | 139 | 2 |
| | 1.5 | FVR1.5E11S-4EN | 106 | 130 | 170 | 106 | 64 | 86.5 | 159 | 2 |
| | 2.2 | FVR2.2E11S-4EN | 106 | 130 | 170 | 106 | 64 | 86.5 | 159 | 2 |
| | 4.0 | FVR4.0E11S-4EN | 170 | 130 | 158 | 86 | 72 | 94.5 | 147 | 3 |
| | 5.5 | FVR5.5E11S-4EN | 180 | 220 | 158 | - | - | 117 | 146 | 4 |
| Single phase 200V | 7.5 | FVR7.5E11S-4EN | 180 | 220 | 158 | - | - | 117 | 146 | 4 |
| | 0.1 | FVR0.1E11S-7EN | 70 | 130 | 96 | 86 | 10 | 38.2 | 85.2 | 1 |
| | 0.2 | FVR0.2E11S-7EN | 70 | 130 | 101 | 86 | 15 | 43.2 | 90.2 | 1 |
| | 0.4 | FVR0.4E11S-7EN | 70 | 130 | 118 | 86 | 32 | 60.2 | 107 | 1 |
| | 0.75 | FVR0.75E11S-7EN | 106 | 130 | 126 | 86 | 40 | 62.5 | 115 | 2 |
| | 1.5 | FVR1.5E11S-7EN | 170 | 130 | 158 | 86 | 72 | 94.5 | 147 | 3 |
| | 2.2 | FVR2.2E11S-7EN | 170 | 130 | 158 | 86 | 72 | 94.5 | 147 | 3 |

Reactor, Filter, and Other Accessories

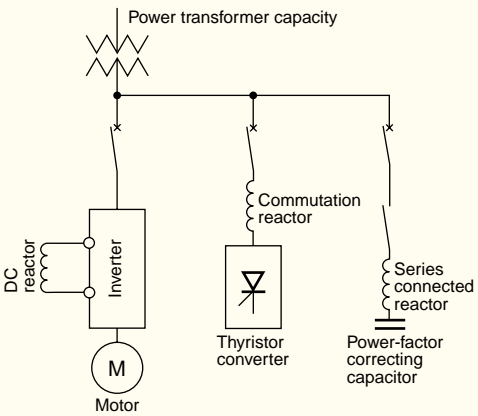
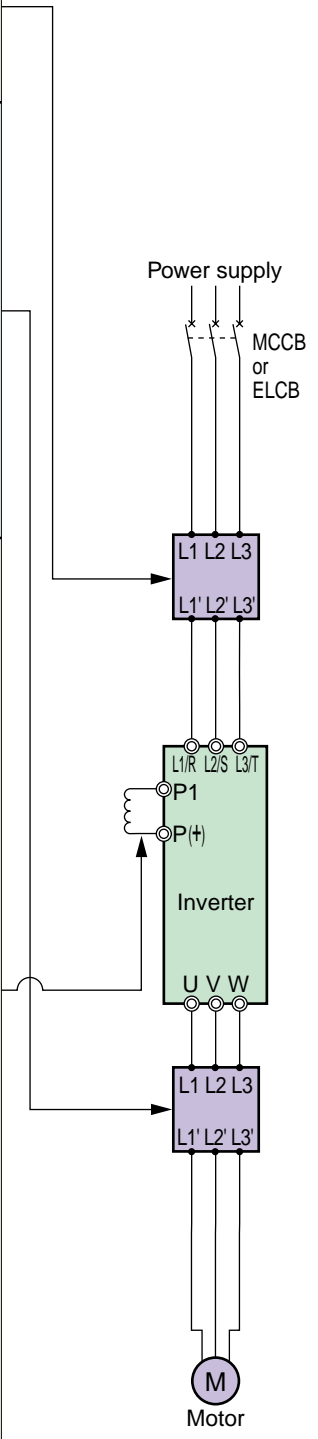
| Name (Type) | Function | Mounting position |
|--|---|--|
| EMC compliance filter (EFL-□□□E11-7) (EFL-□□□E11-4) | This is a special filter which complies with the European EMC (Emission) Directive. This filter should be used together with a ferrite core. <i>Note: Other prerequisites must be fulfilled to ensure compliance with EMC Directives.</i> <i>Refer to this filters operation manual for details.</i> | |
| Output circuit filter (OFL-□□□-4A) | Connected to the output circuit of inverters under low-noise operation with carrier frequency from 8 to 15kHz, this filter has the following functions: 1) Suppressing fluctuation of motor terminal voltage. Protects the motor insulation from being damaged by surge voltage. (400V series) 2) Suppressing leakage current from output side wiring. Reduces the leakage current caused when several motors are operated in parallel or connected with long wiring. * Total wiring length should be less than 400m. 3) Suppressing radial noise or inductive noise from output side wiring. Effective noise suppression device for long wiring applications such as plant. | |
| DC REACTOR(DCR) (DCR4-□□□) (DCR2-□□□) | [Use the DCR to normalize the power supply in the following cases.] 1) The power transformer capacity is 500kVA or over and exceeds the inverter rated capacity by 10 times. 2) The inverter and a thyristor converter are connected with the same transformer. * Check if the thyristor converter uses a commutation reactor. If not, AC reactor must be connected to the power supply side. 3) Overvoltage trip occurs due to open/close of the phase-advancing capacitor for the power supply lines. 4) The voltage unbalance exceeds 2%. $\text{Voltage unbalance (\%)} = \frac{\text{Max. voltage [V]} - \text{Min. Voltage [V]}}{\text{Three-phase average voltage [V]}} \times 67$ (IEC 61800-3 (5.2.3))  |  |
| Copy unit (CP-E11S) | For batch data transfer (read, store, write) between an inverter unit and the copy unit | |

| Name (Type) | Dimension | | | | | | | | | | | | | [Unit: mm] | | | | | | | | | | | | | | | | | | | | | | | | | | | | | | | | | | | | | | | | | | | | | | | | | | | | | | | | | | | | | | | | | | | | | | | | | | | | | | | | | | | | | | | | | | | | | | | | | | | | | | | | | | | | | | | | | | | | | | | | | | | | | | | | | | | | | | | | | | | | | | | | | | | | | | | | | | | | | | | | | | | | | | | | | | | | | |
|--|--------------------------------|------------------------|---|----------------------|----------------------------|---------------|-------------|-------------------|-------------------|----------------------|----------------------------|---------------|--------------------|-------------------|--------------------|-----------|----------------------|-----------------|---|----|---|--------------------------------|-------------|------------------------|---------------|------------|---|----|-----|----|-----|-----|----|----------------|----------|---------------------|--------------|----|----|-----|-------|-----|-----|-----|-----------------|-----------|----------------|--------------|----|----|-----|-------|-----|-----|-----|----------------|----------|---------------------|--------------|----|----|-----|-------|-----|-----|-----|----------------|-------------------|------------|-----------------------|--------------|------------|-----|-----|-----|----|-----|----------------|----------|-----|------|-----------------|---------------|----|-----|-----|----|-----|----------------|----------|-----|----------|---------------------|--------------|----|-----|-----|-----|-----|----------------|----------|-----|----|----|-----|----|------|-----|----|-----|---------------------------------|--|--|--|--|--|--|--|--|--|--|----------------|----------|----|----|----|----|----|-------|----|----|-----|----------------|----------|----|----|----|----|----|-------|----|----|-----|----------------|-----------|----|----|----|----|----|-------|----|----|-----|-----------------|----------|----|----|----|----|----|-------|----|----|-----|----------------|----------|----|----|----|-----|----|-----|-----|----|-----|----------------|----------|----|----|----|-----|----|-----|-----|----|-----|
| EMC Compliance Filter (EFL-□□E11-□) | | | <table border="1"> <thead> <tr> <th rowspan="2">Power supply voltage</th> <th rowspan="2">Nominal applied motor [kW]</th> <th rowspan="2">Inverter type</th> <th rowspan="2">Filter Type</th> <th rowspan="2">Rated voltage [V]</th> <th rowspan="2">Rated current [A]</th> <th rowspan="2">Leakage current [mA]</th> <th colspan="5">Dimensions [mm]</th> <th rowspan="2">Mass [kg]</th> </tr> <tr> <th>W</th> <th>W1</th> <th>H</th> <th>H1</th> <th>D</th> </tr> </thead> <tbody> <tr> <td rowspan="4">Three-phase 400V*</td> <td>0.4 to 0.75</td> <td>FVR0.4 to 0.75E11S-4EN</td> <td>EFL-0.75E11-4</td> <td rowspan="3">380 to 480</td> <td>5</td> <td>12</td> <td>110</td> <td>80</td> <td>191</td> <td>165</td> <td>41</td> <td>0.8</td> </tr> <tr> <td>1.5, 2.2</td> <td>FVR1.5, 2.2E11S-4EN</td> <td>EFL-2.2E11-4</td> <td>10</td> <td>12</td> <td>110</td> <td>80</td> <td>191</td> <td>165</td> <td>41</td> <td>1.0</td> </tr> <tr> <td>4.0</td> <td>FVR4.0E11S-4EN</td> <td>EFL-4.0E11-4</td> <td>15</td> <td>12</td> <td>174</td> <td>145</td> <td>191</td> <td>165</td> <td>46</td> <td>1.4</td> </tr> <tr> <td>5.5, 7.5</td> <td>FVR5.5, 7.5E11S-4EN</td> <td>EFL-7.5E11-4</td> <td>30</td> <td>25</td> <td>182</td> <td>145</td> <td>278</td> <td>252</td> <td>50</td> <td>1.9</td> </tr> <tr> <td rowspan="3">Single-phase 200V</td> <td>0.1 to 0.4</td> <td>FVR0.1 to 0.4E11S-7EN</td> <td>EFL-0.4E11-7</td> <td rowspan="2">200 to 240</td> <td>6.5</td> <td>21</td> <td>71</td> <td>55</td> <td>189</td> <td>178</td> <td>36</td> <td>0.5</td> </tr> <tr> <td>0.75</td> <td>FVR0.75E11S-7EN</td> <td>EFL-0.75E11-7</td> <td>18</td> <td>21</td> <td>110</td> <td>80</td> <td>191</td> <td>165</td> <td>36</td> <td>0.8</td> </tr> <tr> <td>1.5, 2.2</td> <td>FVR1.5, 2.2E11S-7EN</td> <td>EFL-2.2E11-7</td> <td>29</td> <td>21</td> <td>174</td> <td>145</td> <td>191</td> <td>165</td> <td>41</td> <td>1.2</td> </tr> </tbody> </table> | Power supply voltage | Nominal applied motor [kW] | Inverter type | Filter Type | Rated voltage [V] | Rated current [A] | Leakage current [mA] | Dimensions [mm] | | | | | Mass [kg] | W | W1 | H | H1 | D | Three-phase 400V* | 0.4 to 0.75 | FVR0.4 to 0.75E11S-4EN | EFL-0.75E11-4 | 380 to 480 | 5 | 12 | 110 | 80 | 191 | 165 | 41 | 0.8 | 1.5, 2.2 | FVR1.5, 2.2E11S-4EN | EFL-2.2E11-4 | 10 | 12 | 110 | 80 | 191 | 165 | 41 | 1.0 | 4.0 | FVR4.0E11S-4EN | EFL-4.0E11-4 | 15 | 12 | 174 | 145 | 191 | 165 | 46 | 1.4 | 5.5, 7.5 | FVR5.5, 7.5E11S-4EN | EFL-7.5E11-4 | 30 | 25 | 182 | 145 | 278 | 252 | 50 | 1.9 | Single-phase 200V | 0.1 to 0.4 | FVR0.1 to 0.4E11S-7EN | EFL-0.4E11-7 | 200 to 240 | 6.5 | 21 | 71 | 55 | 189 | 178 | 36 | 0.5 | 0.75 | FVR0.75E11S-7EN | EFL-0.75E11-7 | 18 | 21 | 110 | 80 | 191 | 165 | 36 | 0.8 | 1.5, 2.2 | FVR1.5, 2.2E11S-7EN | EFL-2.2E11-7 | 29 | 21 | 174 | 145 | 191 | 165 | 41 | 1.2 | | | | | | | | | | | | | | | | | | | | | | | | | | | | | | | | | | | | | | | | | | | | | | | | | | | | | | | | | | | | | | | | | | | | | | | | | | | | | | | | | | | | | |
| | | | Power supply voltage | | | | | | | | Nominal applied motor [kW] | Inverter type | Filter Type | Rated voltage [V] | Rated current [A] | | Leakage current [mA] | Dimensions [mm] | | | | | Mass [kg] | | | | | | | | | | | | | | | | | | | | | | | | | | | | | | | | | | | | | | | | | | | | | | | | | | | | | | | | | | | | | | | | | | | | | | | | | | | | | | | | | | | | | | | | | | | | | | | | | | | | | | | | | | | | | | | | | | | | | | | | | | | | | | | | | | | | | | | | | | | | | | | | | | | | | | | | | | | | | | | | | | | | |
| W | W1 | H | | H1 | D | | | | | | | | | | | | | | | | | | | | | | | | | | | | | | | | | | | | | | | | | | | | | | | | | | | | | | | | | | | | | | | | | | | | | | | | | | | | | | | | | | | | | | | | | | | | | | | | | | | | | | | | | | | | | | | | | | | | | | | | | | | | | | | | | | | | | | | | | | | | | | | | | | | | | | | | | | | | | | | | | | | | | | | | | | | | | | | | | | | | | | |
| Three-phase 400V* | 0.4 to 0.75 | FVR0.4 to 0.75E11S-4EN | EFL-0.75E11-4 | 380 to 480 | 5 | 12 | 110 | 80 | 191 | 165 | 41 | 0.8 | | | | | | | | | | | | | | | | | | | | | | | | | | | | | | | | | | | | | | | | | | | | | | | | | | | | | | | | | | | | | | | | | | | | | | | | | | | | | | | | | | | | | | | | | | | | | | | | | | | | | | | | | | | | | | | | | | | | | | | | | | | | | | | | | | | | | | | | | | | | | | | | | | | | | | | | | | | | | | | | | | | | | | | | | | | | | | | |
| | 1.5, 2.2 | FVR1.5, 2.2E11S-4EN | EFL-2.2E11-4 | | 10 | 12 | 110 | 80 | 191 | 165 | 41 | 1.0 | | | | | | | | | | | | | | | | | | | | | | | | | | | | | | | | | | | | | | | | | | | | | | | | | | | | | | | | | | | | | | | | | | | | | | | | | | | | | | | | | | | | | | | | | | | | | | | | | | | | | | | | | | | | | | | | | | | | | | | | | | | | | | | | | | | | | | | | | | | | | | | | | | | | | | | | | | | | | | | | | | | | | | | | | | | | | | | |
| | 4.0 | FVR4.0E11S-4EN | EFL-4.0E11-4 | | 15 | 12 | 174 | 145 | 191 | 165 | 46 | 1.4 | | | | | | | | | | | | | | | | | | | | | | | | | | | | | | | | | | | | | | | | | | | | | | | | | | | | | | | | | | | | | | | | | | | | | | | | | | | | | | | | | | | | | | | | | | | | | | | | | | | | | | | | | | | | | | | | | | | | | | | | | | | | | | | | | | | | | | | | | | | | | | | | | | | | | | | | | | | | | | | | | | | | | | | | | | | | | | | |
| | 5.5, 7.5 | FVR5.5, 7.5E11S-4EN | EFL-7.5E11-4 | 30 | 25 | 182 | 145 | 278 | 252 | 50 | 1.9 | | | | | | | | | | | | | | | | | | | | | | | | | | | | | | | | | | | | | | | | | | | | | | | | | | | | | | | | | | | | | | | | | | | | | | | | | | | | | | | | | | | | | | | | | | | | | | | | | | | | | | | | | | | | | | | | | | | | | | | | | | | | | | | | | | | | | | | | | | | | | | | | | | | | | | | | | | | | | | | | | | | | | | | | | | | | | | | | |
| Single-phase 200V | 0.1 to 0.4 | FVR0.1 to 0.4E11S-7EN | EFL-0.4E11-7 | 200 to 240 | 6.5 | 21 | 71 | 55 | 189 | 178 | 36 | 0.5 | | | | | | | | | | | | | | | | | | | | | | | | | | | | | | | | | | | | | | | | | | | | | | | | | | | | | | | | | | | | | | | | | | | | | | | | | | | | | | | | | | | | | | | | | | | | | | | | | | | | | | | | | | | | | | | | | | | | | | | | | | | | | | | | | | | | | | | | | | | | | | | | | | | | | | | | | | | | | | | | | | | | | | | | | | | | | | | |
| | 0.75 | FVR0.75E11S-7EN | EFL-0.75E11-7 | | 18 | 21 | 110 | 80 | 191 | 165 | 36 | 0.8 | | | | | | | | | | | | | | | | | | | | | | | | | | | | | | | | | | | | | | | | | | | | | | | | | | | | | | | | | | | | | | | | | | | | | | | | | | | | | | | | | | | | | | | | | | | | | | | | | | | | | | | | | | | | | | | | | | | | | | | | | | | | | | | | | | | | | | | | | | | | | | | | | | | | | | | | | | | | | | | | | | | | | | | | | | | | | | | |
| | 1.5, 2.2 | FVR1.5, 2.2E11S-7EN | EFL-2.2E11-7 | 29 | 21 | 174 | 145 | 191 | 165 | 41 | 1.2 | | | | | | | | | | | | | | | | | | | | | | | | | | | | | | | | | | | | | | | | | | | | | | | | | | | | | | | | | | | | | | | | | | | | | | | | | | | | | | | | | | | | | | | | | | | | | | | | | | | | | | | | | | | | | | | | | | | | | | | | | | | | | | | | | | | | | | | | | | | | | | | | | | | | | | | | | | | | | | | | | | | | | | | | | | | | | | | | |
| DC REACTOR (DCR□-□□) | External dimensions | | <table border="1"> <thead> <tr> <th rowspan="2">Applicable inverter</th> <th rowspan="2">Reactor type</th> <th colspan="7">Dimensions</th> <th rowspan="2">Terminal hole dia.</th> <th rowspan="2">Mass [kg]</th> </tr> <tr> <th>A</th> <th>B</th> <th>C</th> <th>D</th> <th>E</th> <th>G</th> <th>H</th> </tr> </thead> <tbody> <tr> <td colspan="2">Three-phase 400V series</td> <td></td><td></td><td></td><td></td><td></td><td></td><td></td><td></td><td></td><td></td> </tr> <tr> <td>FVR0.4E11S-4EN</td> <td>DCR4-0.4</td> <td>66</td> <td>56</td> <td>72</td> <td>90</td> <td>15</td> <td>5.2×8</td> <td>94</td> <td>M4</td> <td>1.0</td> </tr> <tr> <td>FVR0.75E11S-4EN</td> <td>DCR4-0.75</td> <td>66</td> <td>56</td> <td>72</td> <td>90</td> <td>20</td> <td>5.2×8</td> <td>94</td> <td>M4</td> <td>1.4</td> </tr> <tr> <td>FVR1.5E11S-4EN</td> <td>DCR4-1.5</td> <td>66</td> <td>56</td> <td>72</td> <td>90</td> <td>20</td> <td>5.2×8</td> <td>94</td> <td>M4</td> <td>1.6</td> </tr> <tr> <td>FVR2.2E11S-4EN</td> <td>DCR4-2.2</td> <td>86</td> <td>71</td> <td>80</td> <td>100</td> <td>10</td> <td>6×9</td> <td>110</td> <td>M4</td> <td>2.0</td> </tr> <tr> <td>FVR4.0E11S-4EN</td> <td>DCR4-4.0</td> <td>86</td> <td>71</td> <td>80</td> <td>100</td> <td>20</td> <td>6×9</td> <td>110</td> <td>M4</td> <td>2.6</td> </tr> <tr> <td>FVR5.5E11S-4EN</td> <td>DCR4-5.5</td> <td>86</td> <td>71</td> <td>80</td> <td>100</td> <td>20</td> <td>6×9</td> <td>110</td> <td>M4</td> <td>2.6</td> </tr> <tr> <td>FVR7.5E11S-4EN</td> <td>DCR4-7.5</td> <td>111</td> <td>95</td> <td>80</td> <td>100</td> <td>23</td> <td>7×11</td> <td>130</td> <td>M5</td> <td>4.2</td> </tr> <tr> <td colspan="2">Single-phase 200V series</td> <td></td><td></td><td></td><td></td><td></td><td></td><td></td><td></td><td></td> </tr> <tr> <td>FVR0.1E11S-7EN</td> <td>DCR2-0.2</td> <td>66</td> <td>56</td> <td>72</td> <td>90</td> <td>20</td> <td>5.2×8</td> <td>94</td> <td>M4</td> <td>0.8</td> </tr> <tr> <td>FVR0.2E11S-7EN</td> <td>DCR2-0.4</td> <td>66</td> <td>56</td> <td>72</td> <td>90</td> <td>20</td> <td>5.2×8</td> <td>94</td> <td>M4</td> <td>1.0</td> </tr> <tr> <td>FVR0.4E11S-7EN</td> <td>DCR2-0.75</td> <td>66</td> <td>56</td> <td>72</td> <td>90</td> <td>15</td> <td>5.2×8</td> <td>94</td> <td>M4</td> <td>1.4</td> </tr> <tr> <td>FVR0.75E11S-7EN</td> <td>DCR2-1.5</td> <td>66</td> <td>56</td> <td>72</td> <td>90</td> <td>20</td> <td>5.2×8</td> <td>94</td> <td>M4</td> <td>1.6</td> </tr> <tr> <td>FVR1.5E11S-7EN</td> <td>DCR2-2.2</td> <td>86</td> <td>71</td> <td>80</td> <td>100</td> <td>20</td> <td>6×9</td> <td>110</td> <td>M4</td> <td>1.8</td> </tr> <tr> <td>FVR2.2E11S-7EN</td> <td>DCR2-3.7</td> <td>86</td> <td>71</td> <td>80</td> <td>100</td> <td>24</td> <td>6×9</td> <td>110</td> <td>M4</td> <td>2.6</td> </tr> </tbody> </table> | Applicable inverter | Reactor type | Dimensions | | | | | | | Terminal hole dia. | Mass [kg] | A | B | C | D | E | G | H | Three-phase 400V series | | | | | | | | | | | | FVR0.4E11S-4EN | DCR4-0.4 | 66 | 56 | 72 | 90 | 15 | 5.2×8 | 94 | M4 | 1.0 | FVR0.75E11S-4EN | DCR4-0.75 | 66 | 56 | 72 | 90 | 20 | 5.2×8 | 94 | M4 | 1.4 | FVR1.5E11S-4EN | DCR4-1.5 | 66 | 56 | 72 | 90 | 20 | 5.2×8 | 94 | M4 | 1.6 | FVR2.2E11S-4EN | DCR4-2.2 | 86 | 71 | 80 | 100 | 10 | 6×9 | 110 | M4 | 2.0 | FVR4.0E11S-4EN | DCR4-4.0 | 86 | 71 | 80 | 100 | 20 | 6×9 | 110 | M4 | 2.6 | FVR5.5E11S-4EN | DCR4-5.5 | 86 | 71 | 80 | 100 | 20 | 6×9 | 110 | M4 | 2.6 | FVR7.5E11S-4EN | DCR4-7.5 | 111 | 95 | 80 | 100 | 23 | 7×11 | 130 | M5 | 4.2 | Single-phase 200V series | | | | | | | | | | | FVR0.1E11S-7EN | DCR2-0.2 | 66 | 56 | 72 | 90 | 20 | 5.2×8 | 94 | M4 | 0.8 | FVR0.2E11S-7EN | DCR2-0.4 | 66 | 56 | 72 | 90 | 20 | 5.2×8 | 94 | M4 | 1.0 | FVR0.4E11S-7EN | DCR2-0.75 | 66 | 56 | 72 | 90 | 15 | 5.2×8 | 94 | M4 | 1.4 | FVR0.75E11S-7EN | DCR2-1.5 | 66 | 56 | 72 | 90 | 20 | 5.2×8 | 94 | M4 | 1.6 | FVR1.5E11S-7EN | DCR2-2.2 | 86 | 71 | 80 | 100 | 20 | 6×9 | 110 | M4 | 1.8 | FVR2.2E11S-7EN | DCR2-3.7 | 86 | 71 | 80 | 100 | 24 | 6×9 | 110 | M4 | 2.6 |
| | | | Applicable inverter | | | Reactor type | Dimensions | | | | | | | | Terminal hole dia. | Mass [kg] | | | | | | | | | | | | | | | | | | | | | | | | | | | | | | | | | | | | | | | | | | | | | | | | | | | | | | | | | | | | | | | | | | | | | | | | | | | | | | | | | | | | | | | | | | | | | | | | | | | | | | | | | | | | | | | | | | | | | | | | | | | | | | | | | | | | | | | | | | | | | | | | | | | | | | | | | | | | | | | | | | | | | | | | | | | |
| A | B | C | | D | E | | G | H | | | | | | | | | | | | | | | | | | | | | | | | | | | | | | | | | | | | | | | | | | | | | | | | | | | | | | | | | | | | | | | | | | | | | | | | | | | | | | | | | | | | | | | | | | | | | | | | | | | | | | | | | | | | | | | | | | | | | | | | | | | | | | | | | | | | | | | | | | | | | | | | | | | | | | | | | | | | | | | | | | | | | | | | | | | | | | | | | | | |
| Three-phase 400V series | | | | | | | | | | | | | | | | | | | | | | | | | | | | | | | | | | | | | | | | | | | | | | | | | | | | | | | | | | | | | | | | | | | | | | | | | | | | | | | | | | | | | | | | | | | | | | | | | | | | | | | | | | | | | | | | | | | | | | | | | | | | | | | | | | | | | | | | | | | | | | | | | | | | | | | | | | | | | | | | | | | | | | | | | | | | | | | | | | | | | | | | | | | |
| FVR0.4E11S-4EN | DCR4-0.4 | 66 | 56 | 72 | 90 | 15 | 5.2×8 | 94 | M4 | 1.0 | | | | | | | | | | | | | | | | | | | | | | | | | | | | | | | | | | | | | | | | | | | | | | | | | | | | | | | | | | | | | | | | | | | | | | | | | | | | | | | | | | | | | | | | | | | | | | | | | | | | | | | | | | | | | | | | | | | | | | | | | | | | | | | | | | | | | | | | | | | | | | | | | | | | | | | | | | | | | | | | | | | | | | | | | | | | | | | | | |
| FVR0.75E11S-4EN | DCR4-0.75 | 66 | 56 | 72 | 90 | 20 | 5.2×8 | 94 | M4 | 1.4 | | | | | | | | | | | | | | | | | | | | | | | | | | | | | | | | | | | | | | | | | | | | | | | | | | | | | | | | | | | | | | | | | | | | | | | | | | | | | | | | | | | | | | | | | | | | | | | | | | | | | | | | | | | | | | | | | | | | | | | | | | | | | | | | | | | | | | | | | | | | | | | | | | | | | | | | | | | | | | | | | | | | | | | | | | | | | | | | | |
| FVR1.5E11S-4EN | DCR4-1.5 | 66 | 56 | 72 | 90 | 20 | 5.2×8 | 94 | M4 | 1.6 | | | | | | | | | | | | | | | | | | | | | | | | | | | | | | | | | | | | | | | | | | | | | | | | | | | | | | | | | | | | | | | | | | | | | | | | | | | | | | | | | | | | | | | | | | | | | | | | | | | | | | | | | | | | | | | | | | | | | | | | | | | | | | | | | | | | | | | | | | | | | | | | | | | | | | | | | | | | | | | | | | | | | | | | | | | | | | | | | |
| FVR2.2E11S-4EN | DCR4-2.2 | 86 | 71 | 80 | 100 | 10 | 6×9 | 110 | M4 | 2.0 | | | | | | | | | | | | | | | | | | | | | | | | | | | | | | | | | | | | | | | | | | | | | | | | | | | | | | | | | | | | | | | | | | | | | | | | | | | | | | | | | | | | | | | | | | | | | | | | | | | | | | | | | | | | | | | | | | | | | | | | | | | | | | | | | | | | | | | | | | | | | | | | | | | | | | | | | | | | | | | | | | | | | | | | | | | | | | | | | |
| FVR4.0E11S-4EN | DCR4-4.0 | 86 | 71 | 80 | 100 | 20 | 6×9 | 110 | M4 | 2.6 | | | | | | | | | | | | | | | | | | | | | | | | | | | | | | | | | | | | | | | | | | | | | | | | | | | | | | | | | | | | | | | | | | | | | | | | | | | | | | | | | | | | | | | | | | | | | | | | | | | | | | | | | | | | | | | | | | | | | | | | | | | | | | | | | | | | | | | | | | | | | | | | | | | | | | | | | | | | | | | | | | | | | | | | | | | | | | | | | |
| FVR5.5E11S-4EN | DCR4-5.5 | 86 | 71 | 80 | 100 | 20 | 6×9 | 110 | M4 | 2.6 | | | | | | | | | | | | | | | | | | | | | | | | | | | | | | | | | | | | | | | | | | | | | | | | | | | | | | | | | | | | | | | | | | | | | | | | | | | | | | | | | | | | | | | | | | | | | | | | | | | | | | | | | | | | | | | | | | | | | | | | | | | | | | | | | | | | | | | | | | | | | | | | | | | | | | | | | | | | | | | | | | | | | | | | | | | | | | | | | |
| FVR7.5E11S-4EN | DCR4-7.5 | 111 | 95 | 80 | 100 | 23 | 7×11 | 130 | M5 | 4.2 | | | | | | | | | | | | | | | | | | | | | | | | | | | | | | | | | | | | | | | | | | | | | | | | | | | | | | | | | | | | | | | | | | | | | | | | | | | | | | | | | | | | | | | | | | | | | | | | | | | | | | | | | | | | | | | | | | | | | | | | | | | | | | | | | | | | | | | | | | | | | | | | | | | | | | | | | | | | | | | | | | | | | | | | | | | | | | | | | |
| Single-phase 200V series | | | | | | | | | | | | | | | | | | | | | | | | | | | | | | | | | | | | | | | | | | | | | | | | | | | | | | | | | | | | | | | | | | | | | | | | | | | | | | | | | | | | | | | | | | | | | | | | | | | | | | | | | | | | | | | | | | | | | | | | | | | | | | | | | | | | | | | | | | | | | | | | | | | | | | | | | | | | | | | | | | | | | | | | | | | | | | | | | | | | | | | | | | | |
| FVR0.1E11S-7EN | DCR2-0.2 | 66 | 56 | 72 | 90 | 20 | 5.2×8 | 94 | M4 | 0.8 | | | | | | | | | | | | | | | | | | | | | | | | | | | | | | | | | | | | | | | | | | | | | | | | | | | | | | | | | | | | | | | | | | | | | | | | | | | | | | | | | | | | | | | | | | | | | | | | | | | | | | | | | | | | | | | | | | | | | | | | | | | | | | | | | | | | | | | | | | | | | | | | | | | | | | | | | | | | | | | | | | | | | | | | | | | | | | | | | |
| FVR0.2E11S-7EN | DCR2-0.4 | 66 | 56 | 72 | 90 | 20 | 5.2×8 | 94 | M4 | 1.0 | | | | | | | | | | | | | | | | | | | | | | | | | | | | | | | | | | | | | | | | | | | | | | | | | | | | | | | | | | | | | | | | | | | | | | | | | | | | | | | | | | | | | | | | | | | | | | | | | | | | | | | | | | | | | | | | | | | | | | | | | | | | | | | | | | | | | | | | | | | | | | | | | | | | | | | | | | | | | | | | | | | | | | | | | | | | | | | | | |
| FVR0.4E11S-7EN | DCR2-0.75 | 66 | 56 | 72 | 90 | 15 | 5.2×8 | 94 | M4 | 1.4 | | | | | | | | | | | | | | | | | | | | | | | | | | | | | | | | | | | | | | | | | | | | | | | | | | | | | | | | | | | | | | | | | | | | | | | | | | | | | | | | | | | | | | | | | | | | | | | | | | | | | | | | | | | | | | | | | | | | | | | | | | | | | | | | | | | | | | | | | | | | | | | | | | | | | | | | | | | | | | | | | | | | | | | | | | | | | | | | | |
| FVR0.75E11S-7EN | DCR2-1.5 | 66 | 56 | 72 | 90 | 20 | 5.2×8 | 94 | M4 | 1.6 | | | | | | | | | | | | | | | | | | | | | | | | | | | | | | | | | | | | | | | | | | | | | | | | | | | | | | | | | | | | | | | | | | | | | | | | | | | | | | | | | | | | | | | | | | | | | | | | | | | | | | | | | | | | | | | | | | | | | | | | | | | | | | | | | | | | | | | | | | | | | | | | | | | | | | | | | | | | | | | | | | | | | | | | | | | | | | | | | |
| FVR1.5E11S-7EN | DCR2-2.2 | 86 | 71 | 80 | 100 | 20 | 6×9 | 110 | M4 | 1.8 | | | | | | | | | | | | | | | | | | | | | | | | | | | | | | | | | | | | | | | | | | | | | | | | | | | | | | | | | | | | | | | | | | | | | | | | | | | | | | | | | | | | | | | | | | | | | | | | | | | | | | | | | | | | | | | | | | | | | | | | | | | | | | | | | | | | | | | | | | | | | | | | | | | | | | | | | | | | | | | | | | | | | | | | | | | | | | | | | |
| FVR2.2E11S-7EN | DCR2-3.7 | 86 | 71 | 80 | 100 | 24 | 6×9 | 110 | M4 | 2.6 | | | | | | | | | | | | | | | | | | | | | | | | | | | | | | | | | | | | | | | | | | | | | | | | | | | | | | | | | | | | | | | | | | | | | | | | | | | | | | | | | | | | | | | | | | | | | | | | | | | | | | | | | | | | | | | | | | | | | | | | | | | | | | | | | | | | | | | | | | | | | | | | | | | | | | | | | | | | | | | | | | | | | | | | | | | | | | | | | |

Wiring equipment

| Power supply voltage | Nominal applied motor [kW] | Inverter type | MCCB or ELCB Rated current [A] | | Fuji Magnetic contactor (MC) | | | Recommended wire size [mm ²] | | | | |
|----------------------|----------------------------|----------------------|--------------------------------|-----------------|------------------------------|-----------------|----------------|--|-----------------|--------------------------|------------------------|-----------------------------|
| | | | With DCR | Without reactor | Input circuit | | Output circuit | Input circuit [L1/R, L2/S, L3/T] | | Output circuit [U, V, W] | DCR circuit [P1, P(+)] | DB circuit [P(+), DB, N(-)] |
| | | | | | With DCR | Without reactor | | With DCR | Without reactor | | | |
| Three-phase 400V | 0.4, 0.75 | FVR0.4, 0.75E11S-4EN | 6 | 6 | SC-05 | SC-05 | SC-05 | 2.5 | 2.5 | 2.5 | 2.5 | 2.5 |
| | 1.5 | FVR1.5E11S-4EN | 6 | 10 | | | | | | | | |
| | 2.2 | FVR2.2E11S-4EN | 6 | 16 | | | | | | | | |
| | 4.0 | FVR4.0E11S-4EN | 10 | 20 | | | | | | | | |
| | 5.5 | FVR5.5E11S-4EN | 16 | 32 | | | | | | | | |
| 7.5 | FVR7.5E11S-4EN | 20 | 35 | | | | | | | | | |
| Single-phase 200V | 0.1, 0.2 | FVR0.1, 0.2E11S-7EN | 6 | 6 | SC-05 | SC-05 | SC-05 | 2.5 | 2.5 | 2.5 | 2.5 | 2.5 |
| | 0.4 | FVR0.4E11S-7EN | | 10 | | | | | | | | |
| | 0.75 | FVR0.75E11S-7EN | | 16 | | | | | | | | |
| | 1.5 | FVR1.5E11S-7EN | | 20 | | | | | | | | |
| | 2.2 | FVR2.2E11S-7EN | | 32 | | | | | | | | |

NOTES :

*1 The applicable frame and series of the molded case circuit breaker (MCCB) and earth leakage circuit breaker (ELCB) vary according to the capacity of the transformer of the equipment. For details of selection, refer to the concerning technical documents.

*2 The recommended wire size for the main circuit is the case for the low voltage directive at ambient temperature 40°C.

*3 The power supply impedance without a reactor is considered to be the equivalent of 0.1% of the inverter capacity, with 10% current imbalance accompanied by the voltage imbalance.

*4 Crimp terminals up to 7.4 mm in width (including tolerance) can be used.

*5 Crimp terminals up to 9.5 mm in width (including tolerance) can be used.

*6 Use the grounding cable of a size equal to or larger than that of the input power supply cable.

| Name (type) | Functions and dimensions | | | | [Unit : mm] | | | | | | | | | | | | | | | | | | | | | | | | | | | | | | | | | | | | | | | | | | | | | | | | | | | | | | | | | | | | | | | | | | | | | | | | | | | | | | | | | | | | | | | | | | | | | | | | | | | | | | | | | | | | | | | | | | | | | | | | | | | | | | | | | | | | | | | | | | | | | | | | | | | | | | | | | | | | | | | | | | | | | | | | | | | | | | | | | | | | | | | | | | | | | | | | | | | | | | | | | | | | | | | | | | | | | | |
|--|---|--------------------------|---------------------|---------------------|---|--------------------|--------------------|--------------------|--------------------|-----------------|---------------------------|-----|------|-----|-----------|------|------|-----|--------------|-------------|----|---|---------------|----------|----------|---|----------------------------|-----|-----|-----|-----|-----|---------|-----|---------------|------|----------|-----|---------|----|---------|---------|---------|------------------------|-----|---|-----|-----|-----|-----|---------|-----------------|-----|----|-----|-----|-----|----|-----|--------------------------|---------|----|----|---|-----|-----|----|-----------------------------------|---------|-----|-----|-----|-----|-----|-----|------------|------|-----------|---------|----------|-----|----------|----------|----------|------------------------|-----|------------|---------|---|-----|-----|-----|-----------------|-----|----|-----|---|---------|----|-----|--------------------------|-----|-----|----|-----|-----------|-----------|----|-----------------------------------|-----|-----|-----|------|-----|----------|----------|--|--------|---------------------|--------------------|--------------------|--------------------|---------------------|--------------------|--------------------|------|---------------------------|-----|-----|-----|------|-----|----------|--------------|-------------|----|---|-----|-----|----|----------------------------|----------|----------|-----|-----|-----|-----|---------------|------|----------|--|--|---------|--|--|------------------------|-----|--|--|-----|--|--|-----------------|-----|--|--|----|--|--|--------------------------|----|----|----|----|---|---|-----------------------------------|-----|-----|-----|-----|-----|-----|------------|------|-----------|--|--|----------|--|--|------------------------|-----|--|--|-----|--|--|-----------------|-----|--|--|----|--|--|--------------------------|----|----|----|----|----|----|-----------------------------------|-----|-----|-----|-----|-----|-----|
| Braking resistor [Standard type] (DB□□□□□) [10%ED type] (DB□□□□□C) | <div style="display: flex; justify-content: space-around;"> <div style="text-align: center;"> <p>[Standard type]</p> <p>Fig. A Fig. B</p> </div> <div style="text-align: center;"> <p>[10%ED type]</p> <p>Fig. C Fig. D</p> </div> </div> | | | | <table border="1"> <thead> <tr> <th rowspan="2"></th> <th colspan="2">Type</th> <th rowspan="2">Fig.</th> <th colspan="5">Dimensions [mm]</th> <th rowspan="2">Mass [kg]</th> </tr> <tr> <th>200V</th> <th>400V</th> <th>W</th> <th>W1</th> <th>H</th> <th>H1</th> <th>D</th> </tr> </thead> <tbody> <tr> <td rowspan="7">Standard type</td> <td>DB0.75-2</td> <td>DB0.75-4</td> <td>A</td> <td>64</td> <td>-</td> <td>310</td> <td>295</td> <td>67</td> <td>1.3</td> </tr> <tr> <td>DB2.2-2</td> <td>-</td> <td>A</td> <td>76</td> <td>-</td> <td>345</td> <td>332</td> <td>94</td> <td>2.0</td> </tr> <tr> <td>-</td> <td>DB2.2-4</td> <td>A</td> <td>64</td> <td>-</td> <td>470</td> <td>455</td> <td>67</td> <td>2.0</td> </tr> <tr> <td>DB3.7-2</td> <td>-</td> <td>A</td> <td>76</td> <td>-</td> <td>345</td> <td>332</td> <td>94</td> <td>2.0</td> </tr> <tr> <td>-</td> <td>DB3.7-4</td> <td>A</td> <td>64</td> <td>-</td> <td>470</td> <td>455</td> <td>67</td> <td>1.7</td> </tr> <tr> <td>DB5.5-2</td> <td>-</td> <td>B</td> <td>142</td> <td>90</td> <td>450</td> <td>430</td> <td>67.5</td> <td>4.5</td> </tr> <tr> <td>-</td> <td>DB5.5-4</td> <td>B</td> <td>142</td> <td>74</td> <td>470</td> <td>455</td> <td>67</td> <td>4.5</td> </tr> <tr> <td rowspan="5">10%ED type</td> <td>DB7.5-2</td> <td>-</td> <td>B</td> <td>156</td> <td>90</td> <td>390</td> <td>370</td> <td>90</td> <td>5.0</td> </tr> <tr> <td>-</td> <td>DB7.5-4</td> <td>B</td> <td>142</td> <td>74</td> <td>520</td> <td>495</td> <td>67</td> <td>5.0</td> </tr> <tr> <td>DB0.75-2C</td> <td>DB0.75-4C</td> <td>C</td> <td>43</td> <td>-</td> <td>221</td> <td>215</td> <td>30.5</td> <td>0.5</td> </tr> <tr> <td>DB2.2-2C</td> <td>DB2.2-4C</td> <td>D</td> <td>67</td> <td>-</td> <td>188</td> <td>172</td> <td>55</td> <td>0.8</td> </tr> <tr> <td>DB3.7-2C</td> <td>DB3.7-4C</td> <td>D</td> <td>67</td> <td>-</td> <td>328</td> <td>312</td> <td>55</td> <td>1.6</td> </tr> <tr> <td>DB5.5-2C</td> <td>DB5.5-4C</td> <td>D</td> <td>80</td> <td>-</td> <td>378</td> <td>362</td> <td>78</td> <td>2.9</td> </tr> <tr> <td>DB7.5-2C</td> <td>DB7.5-4C</td> <td>D</td> <td>80</td> <td>-</td> <td>418</td> <td>402</td> <td>78</td> <td>3.3</td> </tr> </tbody> </table> | | Type | | Fig. | Dimensions [mm] | | | | | Mass [kg] | 200V | 400V | W | W1 | H | H1 | D | Standard type | DB0.75-2 | DB0.75-4 | A | 64 | - | 310 | 295 | 67 | 1.3 | DB2.2-2 | - | A | 76 | - | 345 | 332 | 94 | 2.0 | - | DB2.2-4 | A | 64 | - | 470 | 455 | 67 | 2.0 | DB3.7-2 | - | A | 76 | - | 345 | 332 | 94 | 2.0 | - | DB3.7-4 | A | 64 | - | 470 | 455 | 67 | 1.7 | DB5.5-2 | - | B | 142 | 90 | 450 | 430 | 67.5 | 4.5 | - | DB5.5-4 | B | 142 | 74 | 470 | 455 | 67 | 4.5 | 10%ED type | DB7.5-2 | - | B | 156 | 90 | 390 | 370 | 90 | 5.0 | - | DB7.5-4 | B | 142 | 74 | 520 | 495 | 67 | 5.0 | DB0.75-2C | DB0.75-4C | C | 43 | - | 221 | 215 | 30.5 | 0.5 | DB2.2-2C | DB2.2-4C | D | 67 | - | 188 | 172 | 55 | 0.8 | DB3.7-2C | DB3.7-4C | D | 67 | - | 328 | 312 | 55 | 1.6 | DB5.5-2C | DB5.5-4C | D | 80 | - | 378 | 362 | 78 | 2.9 | DB7.5-2C | DB7.5-4C | D | 80 | - | 418 | 402 | 78 | 3.3 | | | | | | | | | | | | | | | | | | | | | | | | | | | | | | | | | | | | | | | | | | | | | | | | | | | | | | | | | | | | | | | | | | | | | |
| | Type | | Fig. | Dimensions [mm] | | | | | | Mass [kg] | | | | | | | | | | | | | | | | | | | | | | | | | | | | | | | | | | | | | | | | | | | | | | | | | | | | | | | | | | | | | | | | | | | | | | | | | | | | | | | | | | | | | | | | | | | | | | | | | | | | | | | | | | | | | | | | | | | | | | | | | | | | | | | | | | | | | | | | | | | | | | | | | | | | | | | | | | | | | | | | | | | | | | | | | | | | | | | | | | | | | | | | | | | | | | | | | | | | | | | | | | | | | | | | | |
| | 200V | 400V | | W | W1 | H | H1 | D | | | | | | | | | | | | | | | | | | | | | | | | | | | | | | | | | | | | | | | | | | | | | | | | | | | | | | | | | | | | | | | | | | | | | | | | | | | | | | | | | | | | | | | | | | | | | | | | | | | | | | | | | | | | | | | | | | | | | | | | | | | | | | | | | | | | | | | | | | | | | | | | | | | | | | | | | | | | | | | | | | | | | | | | | | | | | | | | | | | | | | | | | | | | | | | | | | | | | | | | | | | | | | | | | | | |
| Standard type | DB0.75-2 | DB0.75-4 | A | 64 | - | 310 | 295 | 67 | 1.3 | | | | | | | | | | | | | | | | | | | | | | | | | | | | | | | | | | | | | | | | | | | | | | | | | | | | | | | | | | | | | | | | | | | | | | | | | | | | | | | | | | | | | | | | | | | | | | | | | | | | | | | | | | | | | | | | | | | | | | | | | | | | | | | | | | | | | | | | | | | | | | | | | | | | | | | | | | | | | | | | | | | | | | | | | | | | | | | | | | | | | | | | | | | | | | | | | | | | | | | | | | | | | | | | | | |
| | DB2.2-2 | - | A | 76 | - | 345 | 332 | 94 | 2.0 | | | | | | | | | | | | | | | | | | | | | | | | | | | | | | | | | | | | | | | | | | | | | | | | | | | | | | | | | | | | | | | | | | | | | | | | | | | | | | | | | | | | | | | | | | | | | | | | | | | | | | | | | | | | | | | | | | | | | | | | | | | | | | | | | | | | | | | | | | | | | | | | | | | | | | | | | | | | | | | | | | | | | | | | | | | | | | | | | | | | | | | | | | | | | | | | | | | | | | | | | | | | | | | | | | |
| | - | DB2.2-4 | A | 64 | - | 470 | 455 | 67 | 2.0 | | | | | | | | | | | | | | | | | | | | | | | | | | | | | | | | | | | | | | | | | | | | | | | | | | | | | | | | | | | | | | | | | | | | | | | | | | | | | | | | | | | | | | | | | | | | | | | | | | | | | | | | | | | | | | | | | | | | | | | | | | | | | | | | | | | | | | | | | | | | | | | | | | | | | | | | | | | | | | | | | | | | | | | | | | | | | | | | | | | | | | | | | | | | | | | | | | | | | | | | | | | | | | | | | | |
| | DB3.7-2 | - | A | 76 | - | 345 | 332 | 94 | 2.0 | | | | | | | | | | | | | | | | | | | | | | | | | | | | | | | | | | | | | | | | | | | | | | | | | | | | | | | | | | | | | | | | | | | | | | | | | | | | | | | | | | | | | | | | | | | | | | | | | | | | | | | | | | | | | | | | | | | | | | | | | | | | | | | | | | | | | | | | | | | | | | | | | | | | | | | | | | | | | | | | | | | | | | | | | | | | | | | | | | | | | | | | | | | | | | | | | | | | | | | | | | | | | | | | | | |
| | - | DB3.7-4 | A | 64 | - | 470 | 455 | 67 | 1.7 | | | | | | | | | | | | | | | | | | | | | | | | | | | | | | | | | | | | | | | | | | | | | | | | | | | | | | | | | | | | | | | | | | | | | | | | | | | | | | | | | | | | | | | | | | | | | | | | | | | | | | | | | | | | | | | | | | | | | | | | | | | | | | | | | | | | | | | | | | | | | | | | | | | | | | | | | | | | | | | | | | | | | | | | | | | | | | | | | | | | | | | | | | | | | | | | | | | | | | | | | | | | | | | | | | |
| | DB5.5-2 | - | B | 142 | 90 | 450 | 430 | 67.5 | 4.5 | | | | | | | | | | | | | | | | | | | | | | | | | | | | | | | | | | | | | | | | | | | | | | | | | | | | | | | | | | | | | | | | | | | | | | | | | | | | | | | | | | | | | | | | | | | | | | | | | | | | | | | | | | | | | | | | | | | | | | | | | | | | | | | | | | | | | | | | | | | | | | | | | | | | | | | | | | | | | | | | | | | | | | | | | | | | | | | | | | | | | | | | | | | | | | | | | | | | | | | | | | | | | | | | | | |
| | - | DB5.5-4 | B | 142 | 74 | 470 | 455 | 67 | 4.5 | | | | | | | | | | | | | | | | | | | | | | | | | | | | | | | | | | | | | | | | | | | | | | | | | | | | | | | | | | | | | | | | | | | | | | | | | | | | | | | | | | | | | | | | | | | | | | | | | | | | | | | | | | | | | | | | | | | | | | | | | | | | | | | | | | | | | | | | | | | | | | | | | | | | | | | | | | | | | | | | | | | | | | | | | | | | | | | | | | | | | | | | | | | | | | | | | | | | | | | | | | | | | | | | | | |
| 10%ED type | DB7.5-2 | - | B | 156 | 90 | 390 | 370 | 90 | 5.0 | | | | | | | | | | | | | | | | | | | | | | | | | | | | | | | | | | | | | | | | | | | | | | | | | | | | | | | | | | | | | | | | | | | | | | | | | | | | | | | | | | | | | | | | | | | | | | | | | | | | | | | | | | | | | | | | | | | | | | | | | | | | | | | | | | | | | | | | | | | | | | | | | | | | | | | | | | | | | | | | | | | | | | | | | | | | | | | | | | | | | | | | | | | | | | | | | | | | | | | | | | | | | | | | | | |
| | - | DB7.5-4 | B | 142 | 74 | 520 | 495 | 67 | 5.0 | | | | | | | | | | | | | | | | | | | | | | | | | | | | | | | | | | | | | | | | | | | | | | | | | | | | | | | | | | | | | | | | | | | | | | | | | | | | | | | | | | | | | | | | | | | | | | | | | | | | | | | | | | | | | | | | | | | | | | | | | | | | | | | | | | | | | | | | | | | | | | | | | | | | | | | | | | | | | | | | | | | | | | | | | | | | | | | | | | | | | | | | | | | | | | | | | | | | | | | | | | | | | | | | | | |
| | DB0.75-2C | DB0.75-4C | C | 43 | - | 221 | 215 | 30.5 | 0.5 | | | | | | | | | | | | | | | | | | | | | | | | | | | | | | | | | | | | | | | | | | | | | | | | | | | | | | | | | | | | | | | | | | | | | | | | | | | | | | | | | | | | | | | | | | | | | | | | | | | | | | | | | | | | | | | | | | | | | | | | | | | | | | | | | | | | | | | | | | | | | | | | | | | | | | | | | | | | | | | | | | | | | | | | | | | | | | | | | | | | | | | | | | | | | | | | | | | | | | | | | | | | | | | | | | |
| | DB2.2-2C | DB2.2-4C | D | 67 | - | 188 | 172 | 55 | 0.8 | | | | | | | | | | | | | | | | | | | | | | | | | | | | | | | | | | | | | | | | | | | | | | | | | | | | | | | | | | | | | | | | | | | | | | | | | | | | | | | | | | | | | | | | | | | | | | | | | | | | | | | | | | | | | | | | | | | | | | | | | | | | | | | | | | | | | | | | | | | | | | | | | | | | | | | | | | | | | | | | | | | | | | | | | | | | | | | | | | | | | | | | | | | | | | | | | | | | | | | | | | | | | | | | | | |
| | DB3.7-2C | DB3.7-4C | D | 67 | - | 328 | 312 | 55 | 1.6 | | | | | | | | | | | | | | | | | | | | | | | | | | | | | | | | | | | | | | | | | | | | | | | | | | | | | | | | | | | | | | | | | | | | | | | | | | | | | | | | | | | | | | | | | | | | | | | | | | | | | | | | | | | | | | | | | | | | | | | | | | | | | | | | | | | | | | | | | | | | | | | | | | | | | | | | | | | | | | | | | | | | | | | | | | | | | | | | | | | | | | | | | | | | | | | | | | | | | | | | | | | | | | | | | | |
| DB5.5-2C | DB5.5-4C | D | 80 | - | 378 | 362 | 78 | 2.9 | | | | | | | | | | | | | | | | | | | | | | | | | | | | | | | | | | | | | | | | | | | | | | | | | | | | | | | | | | | | | | | | | | | | | | | | | | | | | | | | | | | | | | | | | | | | | | | | | | | | | | | | | | | | | | | | | | | | | | | | | | | | | | | | | | | | | | | | | | | | | | | | | | | | | | | | | | | | | | | | | | | | | | | | | | | | | | | | | | | | | | | | | | | | | | | | | | | | | | | | | | | | | | | | | | | |
| DB7.5-2C | DB7.5-4C | D | 80 | - | 418 | 402 | 78 | 3.3 | | | | | | | | | | | | | | | | | | | | | | | | | | | | | | | | | | | | | | | | | | | | | | | | | | | | | | | | | | | | | | | | | | | | | | | | | | | | | | | | | | | | | | | | | | | | | | | | | | | | | | | | | | | | | | | | | | | | | | | | | | | | | | | | | | | | | | | | | | | | | | | | | | | | | | | | | | | | | | | | | | | | | | | | | | | | | | | | | | | | | | | | | | | | | | | | | | | | | | | | | | | | | | | | | | | |
| <table border="1"> <thead> <tr> <th>Series</th> <th>Applicable inverter</th> <th>FVR0.4 E11S-4EN</th> <th>FVR0.75 E11S-4EN</th> <th>FVR1.5 E11S-4EN</th> <th>FVR2.2 E11S-4EN</th> <th>FVR4.0 E11S-4EN</th> <th>FVR5.5 E11S-4EN</th> <th>FVR7.5 E11S-4EN</th> </tr> </thead> <tbody> <tr> <td rowspan="10">400V</td> <td>Applied motor output [kW]</td> <td>0.4</td> <td>0.75</td> <td>1.5</td> <td>2.2</td> <td>4.0</td> <td>5.5</td> <td>7.5</td> </tr> <tr> <td>Braking unit</td> <td colspan="7">Unnecessary</td> </tr> <tr> <td>Average braking torque [%]</td> <td>150</td> <td>150</td> <td>150</td> <td>150</td> <td>150</td> <td>150</td> <td>150</td> </tr> <tr> <td rowspan="4">Standard type</td> <td>Type</td> <td colspan="2">DB0.75-4</td> <td colspan="2">DB2.2-4</td> <td>DB3.7-4</td> <td>DB5.5-4</td> <td>DB7.5-4</td> </tr> <tr> <td>Resistor capacity [kW]</td> <td colspan="2">0.2</td> <td colspan="2">0.4</td> <td>0.4</td> <td>0.8</td> <td>0.9</td> </tr> <tr> <td>Ohmic value [Ω]</td> <td colspan="2">200</td> <td colspan="2">160</td> <td>130</td> <td>80</td> <td>60</td> </tr> <tr> <td>Allowable duty cycle [%]</td> <td>22</td> <td>18</td> <td>10</td> <td>7</td> <td>5</td> <td>5</td> <td>5</td> </tr> <tr> <td>Continuous allowable braking time</td> <td>45s</td> <td>45s</td> <td>45s</td> <td>30s</td> <td>20s</td> <td>20s</td> <td>10s</td> </tr> <tr> <td rowspan="4">10%ED type</td> <td>Type</td> <td colspan="2">DB0.75-4C</td> <td colspan="2">DB2.2-4C</td> <td>DB3.7-4C</td> <td>DB5.5-4C</td> <td>DB7.5-4C</td> </tr> <tr> <td>Resistor capacity [kW]</td> <td colspan="2">0.2</td> <td colspan="2">0.4</td> <td>0.4</td> <td>0.8</td> <td>0.9</td> </tr> <tr> <td>Ohmic value [Ω]</td> <td colspan="2">200</td> <td colspan="2">160</td> <td>130</td> <td>80</td> <td>60</td> </tr> <tr> <td>Allowable duty cycle [%]</td> <td>10</td> <td>10</td> <td>10</td> <td>10</td> <td>10</td> <td>10</td> <td>10</td> </tr> <tr> <td>Continuous allowable braking time</td> <td>45s</td> <td>45s</td> <td>45s</td> <td>30s</td> <td>20s</td> <td>20s</td> <td>10s</td> </tr> </tbody> </table> | Series | Applicable inverter | FVR0.4 E11S-4EN | FVR0.75 E11S-4EN | FVR1.5 E11S-4EN | FVR2.2 E11S-4EN | FVR4.0 E11S-4EN | FVR5.5 E11S-4EN | FVR7.5 E11S-4EN | 400V | Applied motor output [kW] | 0.4 | 0.75 | 1.5 | 2.2 | 4.0 | 5.5 | 7.5 | Braking unit | Unnecessary | | | | | | | Average braking torque [%] | 150 | 150 | 150 | 150 | 150 | 150 | 150 | Standard type | Type | DB0.75-4 | | DB2.2-4 | | DB3.7-4 | DB5.5-4 | DB7.5-4 | Resistor capacity [kW] | 0.2 | | 0.4 | | 0.4 | 0.8 | 0.9 | Ohmic value [Ω] | 200 | | 160 | | 130 | 80 | 60 | Allowable duty cycle [%] | 22 | 18 | 10 | 7 | 5 | 5 | 5 | Continuous allowable braking time | 45s | 45s | 45s | 30s | 20s | 20s | 10s | 10%ED type | Type | DB0.75-4C | | DB2.2-4C | | DB3.7-4C | DB5.5-4C | DB7.5-4C | Resistor capacity [kW] | 0.2 | | 0.4 | | 0.4 | 0.8 | 0.9 | Ohmic value [Ω] | 200 | | 160 | | 130 | 80 | 60 | Allowable duty cycle [%] | 10 | 10 | 10 | 10 | 10 | 10 | 10 | Continuous allowable braking time | 45s | 45s | 45s | 30s | 20s | 20s | 10s | <table border="1"> <thead> <tr> <th>Series</th> <th>Applicable inverter</th> <th>FVR0.1 E11S-7EN</th> <th>FVR0.2 E11S-7EN</th> <th>FVR0.4 E11S-7EN</th> <th>FVR0.75 E11S-7EN</th> <th>FVR1.5 E11S-7EN</th> <th>FVR2.2 E11S-7EN</th> </tr> </thead> <tbody> <tr> <td rowspan="10">200V</td> <td>Applied motor output [kW]</td> <td>0.1</td> <td>0.2</td> <td>0.4</td> <td>0.75</td> <td>1.5</td> <td>2.2</td> </tr> <tr> <td>Braking unit</td> <td colspan="6">Unnecessary</td> </tr> <tr> <td>Average braking torque [%]</td> <td>150</td> <td>150</td> <td>150</td> <td>150</td> <td>150</td> <td>150</td> </tr> <tr> <td rowspan="4">Standard type</td> <td>Type</td> <td colspan="3">DB0.75-2</td> <td colspan="3">DB2.2-2</td> </tr> <tr> <td>Resistor capacity [kW]</td> <td colspan="3">0.2</td> <td colspan="3">0.4</td> </tr> <tr> <td>Ohmic value [Ω]</td> <td colspan="3">100</td> <td colspan="3">40</td> </tr> <tr> <td>Allowable duty cycle [%]</td> <td>25</td> <td>25</td> <td>15</td> <td>12</td> <td>7</td> <td>7</td> </tr> <tr> <td>Continuous allowable braking time</td> <td>60s</td> <td>60s</td> <td>60s</td> <td>60s</td> <td>30s</td> <td>30s</td> </tr> <tr> <td rowspan="4">10%ED type</td> <td>Type</td> <td colspan="3">DB0.75-2C</td> <td colspan="3">DB2.2-2C</td> </tr> <tr> <td>Resistor capacity [kW]</td> <td colspan="3">0.2</td> <td colspan="3">0.4</td> </tr> <tr> <td>Ohmic value [Ω]</td> <td colspan="3">100</td> <td colspan="3">40</td> </tr> <tr> <td>Allowable duty cycle [%]</td> <td>10</td> <td>10</td> <td>10</td> <td>10</td> <td>10</td> <td>10</td> </tr> <tr> <td>Continuous allowable braking time</td> <td>90s</td> <td>90s</td> <td>45s</td> <td>45s</td> <td>45s</td> <td>30s</td> </tr> </tbody> </table> | Series | Applicable inverter | FVR0.1 E11S-7EN | FVR0.2 E11S-7EN | FVR0.4 E11S-7EN | FVR0.75 E11S-7EN | FVR1.5 E11S-7EN | FVR2.2 E11S-7EN | 200V | Applied motor output [kW] | 0.1 | 0.2 | 0.4 | 0.75 | 1.5 | 2.2 | Braking unit | Unnecessary | | | | | | Average braking torque [%] | 150 | 150 | 150 | 150 | 150 | 150 | Standard type | Type | DB0.75-2 | | | DB2.2-2 | | | Resistor capacity [kW] | 0.2 | | | 0.4 | | | Ohmic value [Ω] | 100 | | | 40 | | | Allowable duty cycle [%] | 25 | 25 | 15 | 12 | 7 | 7 | Continuous allowable braking time | 60s | 60s | 60s | 60s | 30s | 30s | 10%ED type | Type | DB0.75-2C | | | DB2.2-2C | | | Resistor capacity [kW] | 0.2 | | | 0.4 | | | Ohmic value [Ω] | 100 | | | 40 | | | Allowable duty cycle [%] | 10 | 10 | 10 | 10 | 10 | 10 | Continuous allowable braking time | 90s | 90s | 45s | 45s | 45s | 30s |
| Series | Applicable inverter | FVR0.4 E11S-4EN | FVR0.75 E11S-4EN | FVR1.5 E11S-4EN | FVR2.2 E11S-4EN | FVR4.0 E11S-4EN | FVR5.5 E11S-4EN | FVR7.5 E11S-4EN | | | | | | | | | | | | | | | | | | | | | | | | | | | | | | | | | | | | | | | | | | | | | | | | | | | | | | | | | | | | | | | | | | | | | | | | | | | | | | | | | | | | | | | | | | | | | | | | | | | | | | | | | | | | | | | | | | | | | | | | | | | | | | | | | | | | | | | | | | | | | | | | | | | | | | | | | | | | | | | | | | | | | | | | | | | | | | | | | | | | | | | | | | | | | | | | | | | | | | | | | | | | | | | | | | | |
| 400V | Applied motor output [kW] | 0.4 | 0.75 | 1.5 | 2.2 | 4.0 | 5.5 | 7.5 | | | | | | | | | | | | | | | | | | | | | | | | | | | | | | | | | | | | | | | | | | | | | | | | | | | | | | | | | | | | | | | | | | | | | | | | | | | | | | | | | | | | | | | | | | | | | | | | | | | | | | | | | | | | | | | | | | | | | | | | | | | | | | | | | | | | | | | | | | | | | | | | | | | | | | | | | | | | | | | | | | | | | | | | | | | | | | | | | | | | | | | | | | | | | | | | | | | | | | | | | | | | | | | | | | | |
| | Braking unit | Unnecessary | | | | | | | | | | | | | | | | | | | | | | | | | | | | | | | | | | | | | | | | | | | | | | | | | | | | | | | | | | | | | | | | | | | | | | | | | | | | | | | | | | | | | | | | | | | | | | | | | | | | | | | | | | | | | | | | | | | | | | | | | | | | | | | | | | | | | | | | | | | | | | | | | | | | | | | | | | | | | | | | | | | | | | | | | | | | | | | | | | | | | | | | | | | | | | | | | | | | | | | | | | | | | | | | | | | | | | | | | |
| | Average braking torque [%] | 150 | 150 | 150 | 150 | 150 | 150 | 150 | | | | | | | | | | | | | | | | | | | | | | | | | | | | | | | | | | | | | | | | | | | | | | | | | | | | | | | | | | | | | | | | | | | | | | | | | | | | | | | | | | | | | | | | | | | | | | | | | | | | | | | | | | | | | | | | | | | | | | | | | | | | | | | | | | | | | | | | | | | | | | | | | | | | | | | | | | | | | | | | | | | | | | | | | | | | | | | | | | | | | | | | | | | | | | | | | | | | | | | | | | | | | | | | | | | |
| | Standard type | Type | DB0.75-4 | | DB2.2-4 | | DB3.7-4 | DB5.5-4 | DB7.5-4 | | | | | | | | | | | | | | | | | | | | | | | | | | | | | | | | | | | | | | | | | | | | | | | | | | | | | | | | | | | | | | | | | | | | | | | | | | | | | | | | | | | | | | | | | | | | | | | | | | | | | | | | | | | | | | | | | | | | | | | | | | | | | | | | | | | | | | | | | | | | | | | | | | | | | | | | | | | | | | | | | | | | | | | | | | | | | | | | | | | | | | | | | | | | | | | | | | | | | | | | | | | | | | | | | | |
| | | Resistor capacity [kW] | 0.2 | | 0.4 | | 0.4 | 0.8 | 0.9 | | | | | | | | | | | | | | | | | | | | | | | | | | | | | | | | | | | | | | | | | | | | | | | | | | | | | | | | | | | | | | | | | | | | | | | | | | | | | | | | | | | | | | | | | | | | | | | | | | | | | | | | | | | | | | | | | | | | | | | | | | | | | | | | | | | | | | | | | | | | | | | | | | | | | | | | | | | | | | | | | | | | | | | | | | | | | | | | | | | | | | | | | | | | | | | | | | | | | | | | | | | | | | | | | | |
| | | Ohmic value [Ω] | 200 | | 160 | | 130 | 80 | 60 | | | | | | | | | | | | | | | | | | | | | | | | | | | | | | | | | | | | | | | | | | | | | | | | | | | | | | | | | | | | | | | | | | | | | | | | | | | | | | | | | | | | | | | | | | | | | | | | | | | | | | | | | | | | | | | | | | | | | | | | | | | | | | | | | | | | | | | | | | | | | | | | | | | | | | | | | | | | | | | | | | | | | | | | | | | | | | | | | | | | | | | | | | | | | | | | | | | | | | | | | | | | | | | | | | |
| | | Allowable duty cycle [%] | 22 | 18 | 10 | 7 | 5 | 5 | 5 | | | | | | | | | | | | | | | | | | | | | | | | | | | | | | | | | | | | | | | | | | | | | | | | | | | | | | | | | | | | | | | | | | | | | | | | | | | | | | | | | | | | | | | | | | | | | | | | | | | | | | | | | | | | | | | | | | | | | | | | | | | | | | | | | | | | | | | | | | | | | | | | | | | | | | | | | | | | | | | | | | | | | | | | | | | | | | | | | | | | | | | | | | | | | | | | | | | | | | | | | | | | | | | | | | |
| | Continuous allowable braking time | 45s | 45s | 45s | 30s | 20s | 20s | 10s | | | | | | | | | | | | | | | | | | | | | | | | | | | | | | | | | | | | | | | | | | | | | | | | | | | | | | | | | | | | | | | | | | | | | | | | | | | | | | | | | | | | | | | | | | | | | | | | | | | | | | | | | | | | | | | | | | | | | | | | | | | | | | | | | | | | | | | | | | | | | | | | | | | | | | | | | | | | | | | | | | | | | | | | | | | | | | | | | | | | | | | | | | | | | | | | | | | | | | | | | | | | | | | | | | | |
| | 10%ED type | Type | DB0.75-4C | | DB2.2-4C | | DB3.7-4C | DB5.5-4C | DB7.5-4C | | | | | | | | | | | | | | | | | | | | | | | | | | | | | | | | | | | | | | | | | | | | | | | | | | | | | | | | | | | | | | | | | | | | | | | | | | | | | | | | | | | | | | | | | | | | | | | | | | | | | | | | | | | | | | | | | | | | | | | | | | | | | | | | | | | | | | | | | | | | | | | | | | | | | | | | | | | | | | | | | | | | | | | | | | | | | | | | | | | | | | | | | | | | | | | | | | | | | | | | | | | | | | | | | | |
| | | Resistor capacity [kW] | 0.2 | | 0.4 | | 0.4 | 0.8 | 0.9 | | | | | | | | | | | | | | | | | | | | | | | | | | | | | | | | | | | | | | | | | | | | | | | | | | | | | | | | | | | | | | | | | | | | | | | | | | | | | | | | | | | | | | | | | | | | | | | | | | | | | | | | | | | | | | | | | | | | | | | | | | | | | | | | | | | | | | | | | | | | | | | | | | | | | | | | | | | | | | | | | | | | | | | | | | | | | | | | | | | | | | | | | | | | | | | | | | | | | | | | | | | | | | | | | | |
| Ohmic value [Ω] | | 200 | | 160 | | 130 | 80 | 60 | | | | | | | | | | | | | | | | | | | | | | | | | | | | | | | | | | | | | | | | | | | | | | | | | | | | | | | | | | | | | | | | | | | | | | | | | | | | | | | | | | | | | | | | | | | | | | | | | | | | | | | | | | | | | | | | | | | | | | | | | | | | | | | | | | | | | | | | | | | | | | | | | | | | | | | | | | | | | | | | | | | | | | | | | | | | | | | | | | | | | | | | | | | | | | | | | | | | | | | | | | | | | | | | | | | |
| Allowable duty cycle [%] | | 10 | 10 | 10 | 10 | 10 | 10 | 10 | | | | | | | | | | | | | | | | | | | | | | | | | | | | | | | | | | | | | | | | | | | | | | | | | | | | | | | | | | | | | | | | | | | | | | | | | | | | | | | | | | | | | | | | | | | | | | | | | | | | | | | | | | | | | | | | | | | | | | | | | | | | | | | | | | | | | | | | | | | | | | | | | | | | | | | | | | | | | | | | | | | | | | | | | | | | | | | | | | | | | | | | | | | | | | | | | | | | | | | | | | | | | | | | | | | |
| Continuous allowable braking time | 45s | 45s | 45s | 30s | 20s | 20s | 10s | | | | | | | | | | | | | | | | | | | | | | | | | | | | | | | | | | | | | | | | | | | | | | | | | | | | | | | | | | | | | | | | | | | | | | | | | | | | | | | | | | | | | | | | | | | | | | | | | | | | | | | | | | | | | | | | | | | | | | | | | | | | | | | | | | | | | | | | | | | | | | | | | | | | | | | | | | | | | | | | | | | | | | | | | | | | | | | | | | | | | | | | | | | | | | | | | | | | | | | | | | | | | | | | | | | | |
| Series | Applicable inverter | FVR0.1 E11S-7EN | FVR0.2 E11S-7EN | FVR0.4 E11S-7EN | FVR0.75 E11S-7EN | FVR1.5 E11S-7EN | FVR2.2 E11S-7EN | | | | | | | | | | | | | | | | | | | | | | | | | | | | | | | | | | | | | | | | | | | | | | | | | | | | | | | | | | | | | | | | | | | | | | | | | | | | | | | | | | | | | | | | | | | | | | | | | | | | | | | | | | | | | | | | | | | | | | | | | | | | | | | | | | | | | | | | | | | | | | | | | | | | | | | | | | | | | | | | | | | | | | | | | | | | | | | | | | | | | | | | | | | | | | | | | | | | | | | | | | | | | | | | | | | | |
| 200V | Applied motor output [kW] | 0.1 | 0.2 | 0.4 | 0.75 | 1.5 | 2.2 | | | | | | | | | | | | | | | | | | | | | | | | | | | | | | | | | | | | | | | | | | | | | | | | | | | | | | | | | | | | | | | | | | | | | | | | | | | | | | | | | | | | | | | | | | | | | | | | | | | | | | | | | | | | | | | | | | | | | | | | | | | | | | | | | | | | | | | | | | | | | | | | | | | | | | | | | | | | | | | | | | | | | | | | | | | | | | | | | | | | | | | | | | | | | | | | | | | | | | | | | | | | | | | | | | | | |
| | Braking unit | Unnecessary | | | | | | | | | | | | | | | | | | | | | | | | | | | | | | | | | | | | | | | | | | | | | | | | | | | | | | | | | | | | | | | | | | | | | | | | | | | | | | | | | | | | | | | | | | | | | | | | | | | | | | | | | | | | | | | | | | | | | | | | | | | | | | | | | | | | | | | | | | | | | | | | | | | | | | | | | | | | | | | | | | | | | | | | | | | | | | | | | | | | | | | | | | | | | | | | | | | | | | | | | | | | | | | | | | | | | | | | | |
| | Average braking torque [%] | 150 | 150 | 150 | 150 | 150 | 150 | | | | | | | | | | | | | | | | | | | | | | | | | | | | | | | | | | | | | | | | | | | | | | | | | | | | | | | | | | | | | | | | | | | | | | | | | | | | | | | | | | | | | | | | | | | | | | | | | | | | | | | | | | | | | | | | | | | | | | | | | | | | | | | | | | | | | | | | | | | | | | | | | | | | | | | | | | | | | | | | | | | | | | | | | | | | | | | | | | | | | | | | | | | | | | | | | | | | | | | | | | | | | | | | | | | | |
| | Standard type | Type | DB0.75-2 | | | DB2.2-2 | | | | | | | | | | | | | | | | | | | | | | | | | | | | | | | | | | | | | | | | | | | | | | | | | | | | | | | | | | | | | | | | | | | | | | | | | | | | | | | | | | | | | | | | | | | | | | | | | | | | | | | | | | | | | | | | | | | | | | | | | | | | | | | | | | | | | | | | | | | | | | | | | | | | | | | | | | | | | | | | | | | | | | | | | | | | | | | | | | | | | | | | | | | | | | | | | | | | | | | | | | | | | | | | | | | | | |
| | | Resistor capacity [kW] | 0.2 | | | 0.4 | | | | | | | | | | | | | | | | | | | | | | | | | | | | | | | | | | | | | | | | | | | | | | | | | | | | | | | | | | | | | | | | | | | | | | | | | | | | | | | | | | | | | | | | | | | | | | | | | | | | | | | | | | | | | | | | | | | | | | | | | | | | | | | | | | | | | | | | | | | | | | | | | | | | | | | | | | | | | | | | | | | | | | | | | | | | | | | | | | | | | | | | | | | | | | | | | | | | | | | | | | | | | | | | | | | | | |
| | | Ohmic value [Ω] | 100 | | | 40 | | | | | | | | | | | | | | | | | | | | | | | | | | | | | | | | | | | | | | | | | | | | | | | | | | | | | | | | | | | | | | | | | | | | | | | | | | | | | | | | | | | | | | | | | | | | | | | | | | | | | | | | | | | | | | | | | | | | | | | | | | | | | | | | | | | | | | | | | | | | | | | | | | | | | | | | | | | | | | | | | | | | | | | | | | | | | | | | | | | | | | | | | | | | | | | | | | | | | | | | | | | | | | | | | | | | | |
| | | Allowable duty cycle [%] | 25 | 25 | 15 | 12 | 7 | 7 | | | | | | | | | | | | | | | | | | | | | | | | | | | | | | | | | | | | | | | | | | | | | | | | | | | | | | | | | | | | | | | | | | | | | | | | | | | | | | | | | | | | | | | | | | | | | | | | | | | | | | | | | | | | | | | | | | | | | | | | | | | | | | | | | | | | | | | | | | | | | | | | | | | | | | | | | | | | | | | | | | | | | | | | | | | | | | | | | | | | | | | | | | | | | | | | | | | | | | | | | | | | | | | | | | | |
| | Continuous allowable braking time | 60s | 60s | 60s | 60s | 30s | 30s | | | | | | | | | | | | | | | | | | | | | | | | | | | | | | | | | | | | | | | | | | | | | | | | | | | | | | | | | | | | | | | | | | | | | | | | | | | | | | | | | | | | | | | | | | | | | | | | | | | | | | | | | | | | | | | | | | | | | | | | | | | | | | | | | | | | | | | | | | | | | | | | | | | | | | | | | | | | | | | | | | | | | | | | | | | | | | | | | | | | | | | | | | | | | | | | | | | | | | | | | | | | | | | | | | | | |
| | 10%ED type | Type | DB0.75-2C | | | DB2.2-2C | | | | | | | | | | | | | | | | | | | | | | | | | | | | | | | | | | | | | | | | | | | | | | | | | | | | | | | | | | | | | | | | | | | | | | | | | | | | | | | | | | | | | | | | | | | | | | | | | | | | | | | | | | | | | | | | | | | | | | | | | | | | | | | | | | | | | | | | | | | | | | | | | | | | | | | | | | | | | | | | | | | | | | | | | | | | | | | | | | | | | | | | | | | | | | | | | | | | | | | | | | | | | | | | | | | | | |
| | | Resistor capacity [kW] | 0.2 | | | 0.4 | | | | | | | | | | | | | | | | | | | | | | | | | | | | | | | | | | | | | | | | | | | | | | | | | | | | | | | | | | | | | | | | | | | | | | | | | | | | | | | | | | | | | | | | | | | | | | | | | | | | | | | | | | | | | | | | | | | | | | | | | | | | | | | | | | | | | | | | | | | | | | | | | | | | | | | | | | | | | | | | | | | | | | | | | | | | | | | | | | | | | | | | | | | | | | | | | | | | | | | | | | | | | | | | | | | | | |
| Ohmic value [Ω] | | 100 | | | 40 | | | | | | | | | | | | | | | | | | | | | | | | | | | | | | | | | | | | | | | | | | | | | | | | | | | | | | | | | | | | | | | | | | | | | | | | | | | | | | | | | | | | | | | | | | | | | | | | | | | | | | | | | | | | | | | | | | | | | | | | | | | | | | | | | | | | | | | | | | | | | | | | | | | | | | | | | | | | | | | | | | | | | | | | | | | | | | | | | | | | | | | | | | | | | | | | | | | | | | | | | | | | | | | | | | | | | | |
| Allowable duty cycle [%] | | 10 | 10 | 10 | 10 | 10 | 10 | | | | | | | | | | | | | | | | | | | | | | | | | | | | | | | | | | | | | | | | | | | | | | | | | | | | | | | | | | | | | | | | | | | | | | | | | | | | | | | | | | | | | | | | | | | | | | | | | | | | | | | | | | | | | | | | | | | | | | | | | | | | | | | | | | | | | | | | | | | | | | | | | | | | | | | | | | | | | | | | | | | | | | | | | | | | | | | | | | | | | | | | | | | | | | | | | | | | | | | | | | | | | | | | | | | | |
| Continuous allowable braking time | 90s | 90s | 45s | 45s | 45s | 30s | | | | | | | | | | | | | | | | | | | | | | | | | | | | | | | | | | | | | | | | | | | | | | | | | | | | | | | | | | | | | | | | | | | | | | | | | | | | | | | | | | | | | | | | | | | | | | | | | | | | | | | | | | | | | | | | | | | | | | | | | | | | | | | | | | | | | | | | | | | | | | | | | | | | | | | | | | | | | | | | | | | | | | | | | | | | | | | | | | | | | | | | | | | | | | | | | | | | | | | | | | | | | | | | | | | | | |
| Extension cable with adapter for Keypad panel (CBR-5S) | <div style="display: flex; justify-content: space-around; align-items: center;"> <div style="text-align: center;"> <p>Cable</p> </div> <div style="text-align: center;"> <p>Adapter</p> </div> </div> | | | | | | | | | | | | | | | | | | | | | | | | | | | | | | | | | | | | | | | | | | | | | | | | | | | | | | | | | | | | | | | | | | | | | | | | | | | | | | | | | | | | | | | | | | | | | | | | | | | | | | | | | | | | | | | | | | | | | | | | | | | | | | | | | | | | | | | | | | | | | | | | | | | | | | | | | | | | | | | | | | | | | | | | | | | | | | | | | | | | | | | | | | | | | | | | | | | | | | | | | | | | | | | | | | | | | | | | | | |



NOTES

In running general-purpose motors

• Driving a 400V general-purpose motor

When driving a 400V general-purpose motor with an inverter using extremely long cables, damage to the insulation of the motor may occur. Use an output circuit filter (OFL) if necessary after checking with the motor manufacturer. Fuji's motors do not require the use of output circuit filters because of their reinforced insulation.

• Torque characteristics and temperature rise

When the inverter is used to run a general-purpose motor, the temperature of the motor becomes higher than when it is operated using a commercial power supply. In the low-speed range, the cooling effect will be weakened, so decrease the output torque of the motor. If constant torque is required in the low-speed range, use a Fuji inverter motor or a motor equipped with an externally powered ventilating fan.

• Vibration

Use of an inverter does not increase vibration of a general-purpose motor, but when the motor is mounted to a machine, resonance may be caused by the natural frequencies, including that of the machine system.

* The use of a rubber coupling or vibration dampening rubber is recommended.

* It is also recommended to use the inverter jump frequency control to avoid resonance points.

Note that operation of a 2-pole motor at 60Hz or more may cause abnormal vibration.

• Noise

When an inverter is used with a general-purpose motor, the motor noise level is higher than that with a commercial power supply. To reduce noise, raise carrier frequency of the inverter. High-speed operation at 60Hz or more can also result in more noise.

In running special motors

• High-speed motors

If the set frequency is set to 120Hz or more to drive a high-speed motor, test-run the combination of the inverter and motor beforehand to check for safe operation.

• Explosion-proof motors

When driving an explosion-proof motor with an inverter, use a combination of a motor and an inverter that has been approved in advance.

• Submersible motors and pumps

These motors have a larger rated current than general-purpose motors. Select an inverter whose rated output current is greater than that of the motor. These motors differ from general-purpose motors in thermal characteristics. Set a low value in the thermal time constant of the motor when setting the electronic thermal facility.

• Brake motors

For motors equipped with parallel-connected brakes, their braking power must be supplied from the inverter input side (the primary circuit). If the brake power is connected to the inverter power output side (the secondary circuit) by mistake, problems may occur.

Do not use inverters for driving motors equipped with series-connected brakes.

• Geared motors

If the power transmission mechanism uses an oil-lubricated gearbox or speed changer/reducer, then continuous motor operation at low speed may

cause poor lubrication. Avoid such operation.

• Synchronous motors

It is necessary to use software suitable for this motor type. Contact Fuji for details.

• Single-phase motors

Single-phase motors are not suitable for inverter-driven variable speed operation. Use three-phase motors.

* Even if a single-phase power supply is available, use a three-phase motor as the inverter provides three-phase output.

Environmental conditions

• Installation location

Use the inverter in a location with an ambient temperature range of -10 to 50°C.

The inverter heat sinks and braking resistor surfaces become hot under certain operating conditions. Install the inverter on nonflammable material such as metal.

Ensure that the installation location meets the environmental conditions specified in "Environment" in Common specifications on page 11.

Combination with peripheral devices

• Installing a molded case circuit breaker (MCCB) or earth leakage circuit breaker (ELCB)

Install a recommended molded case circuit breaker (MCCB) or an earth leakage circuit breaker (ELCB) (with the exception of those exclusively designed for protection from ground faults) in the primary circuit of the inverter to protect the wiring. Ensure that the circuit breaker capacity is equivalent to or lower than the recommended capacity.

• Installing a magnetic contactor (MC) on the inverter power output side (the secondary circuit)

If a magnetic contactor (MC) is mounted on the inverter power output side (the secondary circuit) for switching the motor to commercial power or for any other purpose, turn the MC on or off while both the inverter and the motor are fully stopped.

Remove the surge suppressor integrated with the MC.

• Installing a magnetic contactor (MC) on the inverter input side (the primary circuit)

Do not turn the magnetic contactor (MC) on the inverter input side (the primary circuit) on or off more than once an hour as an inverter fault may result. If frequent starts or stops are required during motor operation, use FWD/REV signals.

• Protecting the motor

When driving a motor with an inverter, the electronic thermal facility of the inverter can protect the motor. The operation level and the motor type (general-purpose motor, inverter motor) should be set. For high-speed motors or water-cooled motors, set a small value for the thermal time constant to protect the motor, in combination with the "cooling system OFF" signal.

If you connect the motor thermal relay to the motor with a long cable, a high-frequency current may flow into the wiring stray capacitance. This may cause the relay to trip at a current lower than the set value for the thermal relay. If this happens, lower the carrier frequency or use the output circuit filter (OFL).

• Discontinuance of power-factor correcting capacitor

Do not mount power factor correcting capacitors in the inverter primary circuit. (Use the DC REACTOR

to improve the inverter power factor.) Do not use power factor correcting capacitors in the inverter output circuit. An overcurrent trip will occur, disabling motor operation.

• Discontinuance of surge killer

Do not mount surge killers in the inverter secondary circuit.

• Reducing noise

Use of a filter and shielded wires are typical measures against noise to ensure that EMC Directives are met. Refer to Appendices, App. A "Advantageous Use of Inverters (Notes on electrical noise)" for details.

• Measures against surge currents

If an overvoltage trip occurs while the inverter is stopped or operated under a light load, it is assumed that the surge current is generated by open/close of the phase-advancing capacitor in the power system.

* Connect a DC REACTOR to the inverter.

• Megger test

When checking the insulation resistance of the inverter, use a 500V megger and follow the instructions contained in the FVR-E11S Instruction Manual.

Wiring

• Control circuit wiring length

When using remote control, limit the wiring length between the inverter and operator box to 20m or less and use twisted shielded cable.

• Wiring length between inverter and motor

If long wiring is used between the inverter and the motor, the inverter will overheat or trip as a result of overcurrent (high-frequency current flowing into the stray capacitance) in the wires connected to the phases. Ensure that the wiring is shorter than 50m for 3.7kW or less, and shorter than 100m for 5.5kW or more. If this length must be exceeded, lower the carrier frequency or mount an output circuit filter (OFL).

• Wiring size

Select cables with a sufficient capacity by referring to the current value or recommended wire size.

• Wiring type

Do not use multicore cables.

• Grounding

Securely ground the inverter using the grounding terminal.

Selecting inverter capacity

• Driving general-purpose motor

Select an inverter according to the applicable motor ratings listed in the standard specifications table for the inverter. When high starting torque is required or quick acceleration or deceleration is required, select an inverter with a capacity one size greater than the standard.

• Driving special motors

Select an inverter that meets the following condition:
Inverter rated current > Motor rated current

Transportation and storage

When transporting or storing inverters or inverters while mounted on machines, follow the procedures and select locations that meet the environmental conditions listed in the FVR-E11S Instruction Manual.

Fuji Electric FA Components & Systems Co., Ltd.

Gate City Ohsaki, East Tower, 11-2, Osaki 1-chome
Shinagawa-ku, Tokyo 141-0032, Japan
Phone: +81-3-5435-7139 Fax: +81-3-5435-7458

Fuji Electric FA Europe GmbH, D
info_inverter@fujielectric.de
Fax: +49-69-669029-58



Printed on 100% recycled paper